

COBURN

SLIDING SYSTEMS

Hillaldam Coburn Ltd.
Unit 16 Merton Industrial Park
Lee Road
London SW193HX UK
Phone (44) 020 8545 6680
Fax (44) 020 8545 6720
www.coburn.co.uk
sales@hillaldam.co.uk

HIDEAWAY™ SERIES POCKET DOOR FRAME

For 25mm (1") to 44mm (1-3/4")
doors to 56 kgs. (125 lbs.).
(90 kgs. (200 lbs.) on H42)
*With 44mm (1-3/4") doors,
use 61900 Adaptor Kit.

MADE FOR 50mm X 100mm (2" X 4") STUD WALLS

HIDEAWAY™ SERIES SET NUMBERS AND SIZES

**H30 FOR 1-762mm (30") X 2,04m(80.3") Door	H42A FOR 1-1067mm (42") X 2,74m(108") Door
**H36 FOR 1-913mm (36") X 2,04m (80.3") Door	H48A FOR 1-1219mm (48") X 2,74m (108") Door
H42 FOR 1-1067mm (42") X 2,04m (80.3") Door	H54 FOR 1-1371mm (54") X 2,74m (108") Door
**All purpose frames, marked to cut to shorter lengths.	H60A for 1-1524mm (60") X 2,74m (108") Door

DOORS MEETING REQUIRE TWO KITS AND THE 61600 JOINTING KIT.
Frames for Doors up to 1,27m (60") wide and 2,74m (108") high are available.

NOTE: Instructions are for a 2,04m (80.3") door, if door is shorter, lower header and cut bottom ends of Split Studs, if door is taller than 2,04m (80.3"), order longer Split Studs and raise header.

1 CONSTRUCT ROUGH OPENING Header must be **SQUARE** and **PLUMB** with studs and **LEVEL**. Minimum Height is 2,14m (84-1/2") width is 2X Door width plus 25mm (1").

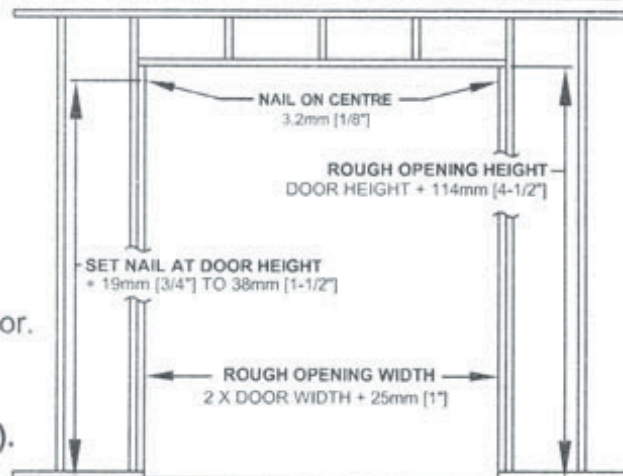

2 Measure up from finished floor 2,05m (80-3/4") or from sub-floor 2,07m (81-1/2"). This will give 12mm (1/2") to 30mm (1-3/16") clearance under door. Mark each rough stud and drive a flat head nail on centre, leaving 3mm (1/8") protruding. (Frame header end brackets will rest on these nails).

3 Make a chalk line on floor even with side jambs.

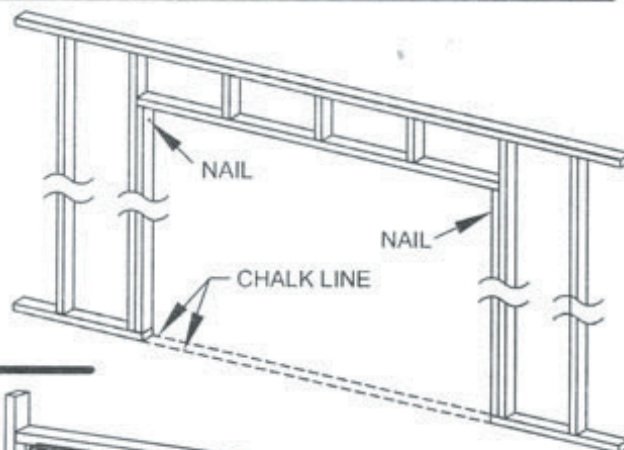

4 Slip slots in Frame Header End Plates over nails in rough studs. **LEVEL HEADER**. Set nails and drive nails through remaining holes in end plates. (If you have the 761mm (2/6") or Universal Frame and using another size door, see cutting instructions on page 4.)

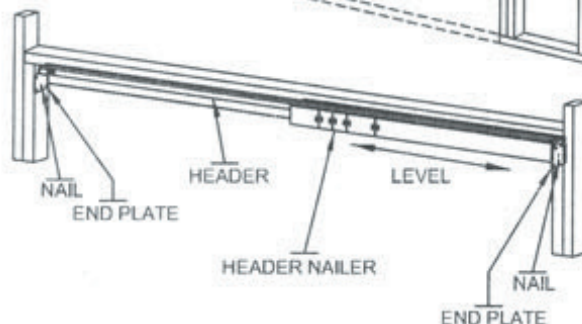

- 5** (Note: If using 44mm (1-3/4") door, use 61900 Adaptor Kit.) Slip fingers of Floor Plate into Split Studs as shown. Butt Split Studs against header nailer and nail into place. Nail other Split Stud midway in "Pocket" opening. Plumb Split Studs between chalk lines and nail to floor. (On masonry, use industrial adhesive or Masonry fasteners.)

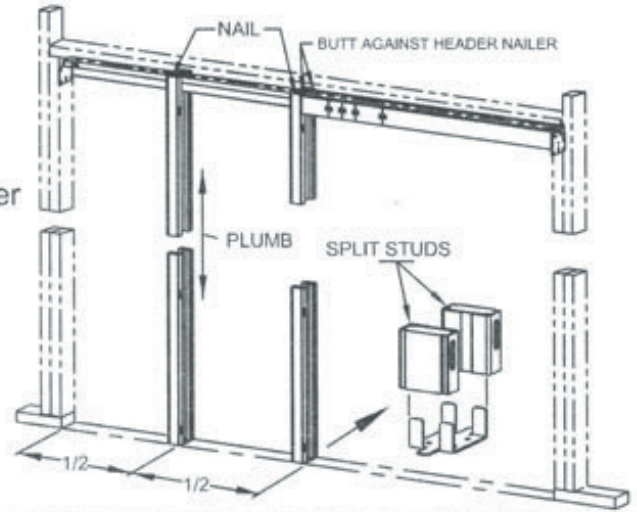

- 6** Apply desired wall material. Wall material is brought clear to edge of opening. **WARNING:** Use nails no longer than necessary. Nails must not protrude into pocket or door will be damaged. To provide a firm nailing surface, slip a 54mm (2-1/8") wide board between Split Studs temporarily.

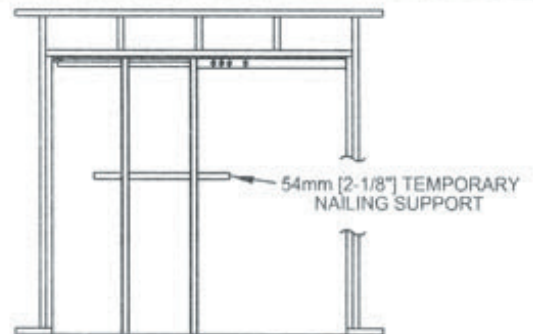

- 7** Seal all edges and face of door panel with paint or sealing stain.

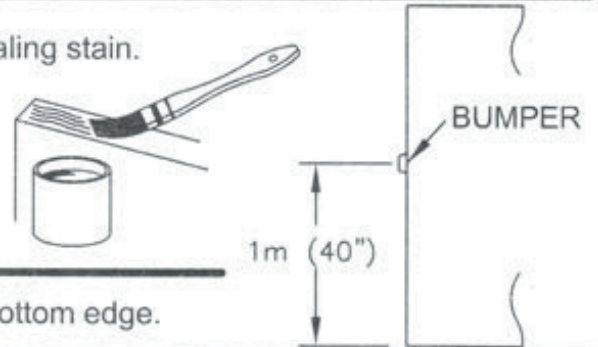

- 8** Fasten Bumper on back edge of door 1m (40") from bottom edge.

- 9** **A/Attach** Door Plates on top of door 50mm (2") from each edge with lock tab on same side.
B/ Insert Hangers into track alternating wheel positions for even weight distribution.
C/ Mount door by locating Door Plate under adjusting bolt of Hanger. Lift door and push bolt into door plate. Repeat with other hanger/door plate.

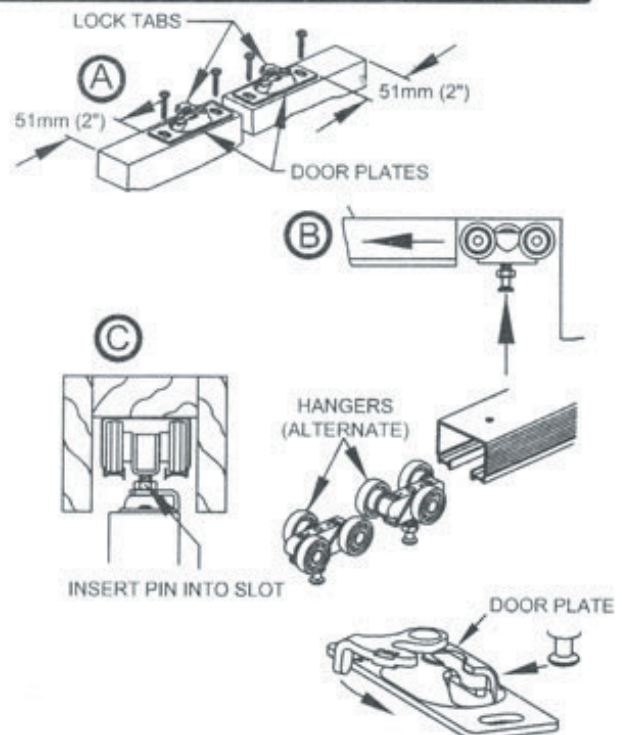

- 10** Install finished jambs, split header and casing (not furnished by Coburn) as shown. Fasten split header on Door plate lock lever side with screws for future door removal or adjustment.
DO NOT USE JAMBS WITH DADOS.
 Note: minimum 5mm (3/16") clearance between jamb and door.

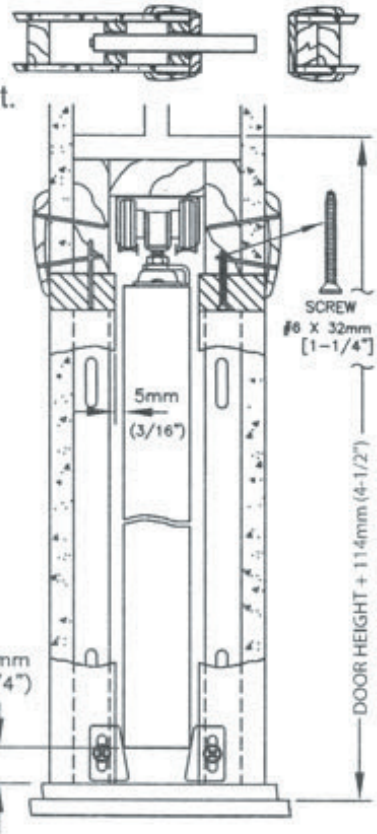

WRENCH

ATTACH FINISH SPLIT JAMB TO STEEL STUD/ PLUMB DOOR WITH JAMB

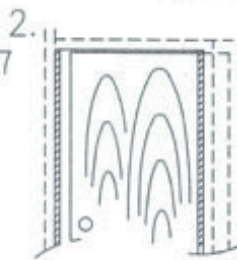
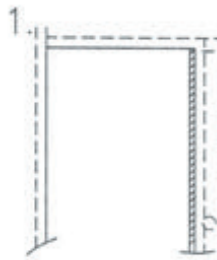

SHIM AND PLUMB FINISH JAMB WITH DOOR

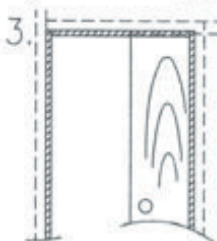

FINISH SPLIT HEADER

FINISH TRIM (not by Coburn)

- 11** Fasten Guides on finished split jambs (not by Coburn) at door bottom so door is held in centre of opening.

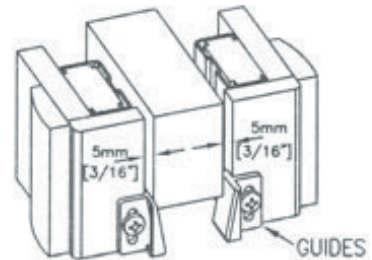

HIDEAWAY™ POCKET DOOR FRAME ADAPTOR KIT

USE WITH 44mm (1-3/4") DOORS
 CATALOGUE No. 61900

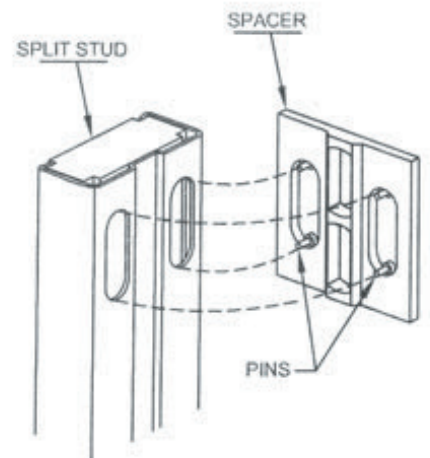
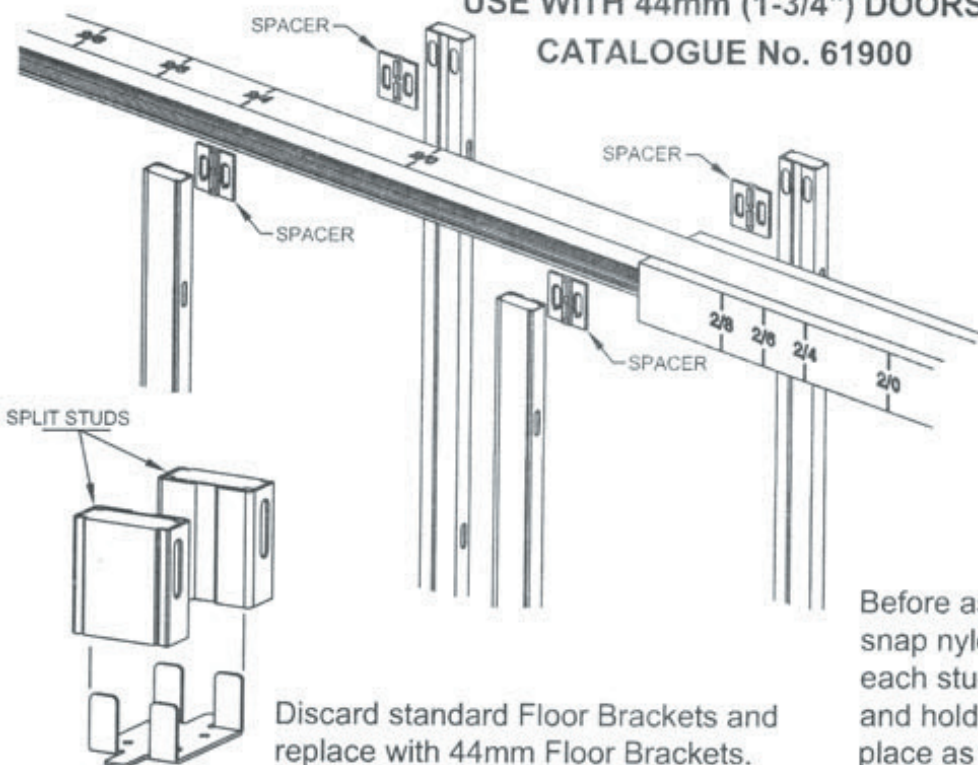

Discard standard Floor Brackets and replace with 44mm Floor Brackets.

Before assembling Split Studs to Header, snap nylon space pads onto top end of each stud. (Small pins fit into nailer slots and hold spacers in place). Nail studs into place as instructed in assembly instructions.

CUTTING INSTRUCTIONS POCKET DOOR FRAME HEADER

762mm [2/6"] and 914mm [3/0"] Pocket Door Frames
are marked for cutting to
shorter standard door widths.

- 1** Remove Adjustable End Bracket.

ADJUSTABLE END BRACKET

2/8	=	81cm	[32"]
2/6	=	76cm	[30"]
2/4	=	71cm	[28"]
2/0	=	61cm	[24"]

- 2** At desired door size marking, cut wood header only.

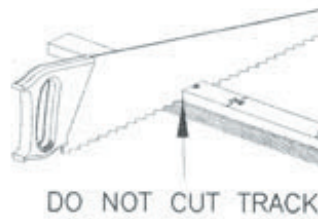

2/8
2/6
2/4
2/0

- 3** Turn header over and cut track 35mm [1-3/8"] shorter than header.

35mm [1-3/8"]

- 4** Replace Adjustable End Bracket on new cut end of header.



- 5** Turn Header on side and cut Header Trim Board ONLY at proper mark. Remove cut off end and discard.

- 6** Turn Header and cut other side.

COBURN
SLIDING SYSTEMS

Cutting header for other than standard door width:
Measure door width and multiply by 2, Add 25mm (1").
Mark header and cut (Step #2). Cut track (Step #3).
Measure door width, Add 25mm (1"). Mark header
Trim board and cut (Step #5 & #6).