

GEZE TS1500 Overhead Door Closer



Installation Instructions

WARNING: DOOR CLOSERS WITH A POWER RATING LOWER THAN 3 OR WITH MECHANICAL HOLD OPEN DEVICES ARE NOT SUITABLE FOR USE WITH FIRE DOORS.

Components Checklist:

- | | |
|--------------------------|---|
| 1x Closer body & cover | 4x 5x55mm Self-tapping countersunk screws |
| 1x Guide Rail Assembly | 2x M5x40mm Countersunk screws |
| | 4x M5x55mm Countersunk screws |
| 2x M6 Allen Bolts | 2x 5x50 Self-tapping countersunk screws |
| 2x Plastic end caps | |
| 1x Plastic spindle cover | |

Tools Required For Installation:

- | | |
|-----------------------|---|
| Flat head screwdriver | 10mm Spanner |
| Posidrive screwdriver | 5mm Allen key (supplied) |
| Power drill | M5 Tap and Tap wrench (steel door mounting) |
| 4.2mm drill bit | |
| Template (supplied) | |
| Pencil | |

User Information for Door Closers

This information must be observed. Non compliance will absolve the manufacture from any liability. The door closer must only be used in accordance with its intended use; i.e. closing of side hung doors following manual opening.

Incorrect use may cause injury

- Obstruction of closing process (e.g. dragging doors, sticking weather strips/sealing rubbers, rough-running locks)
- Incorrect installation and adjustment (e.g. slamming doors)
- Danger of finger trap between frame and door leaf.
- Wrong size door closer.
- Closer used for other purpose than to close side hung doors.

Maintenance:

NOTE:

- Maintenance to be carried out by a specialist only.
- Check assembly for tolerance and undue wear.
- Tighten any screws that may have become loose.

At least once a year:

- Grease moveable parts.
- Check operation of doors and adjust if necessary.
- For door closers subject to release by Electro Mechanical and Electro Hydraulic means ensure that local regulation are adhered to.

Installation and adjustment by specialist only

Where necessary, an additional doorstop or buffer must be fitted to limit the maximum opening of the door. This is of particular relevance for slide rail closers where the opening angle may be limited by frame. For further explanations see catalogue preface and product information.

Door handing - DIN left / right

Stand facing the door on the hinge side / pull side. If the hinge or pivot is to your right hand side the door is considered to be DIN right. If the hinge or pivot is to your left hand side the door is considered to be DIN left.

TS1500 BODY

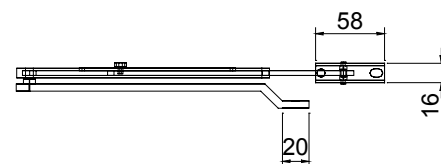
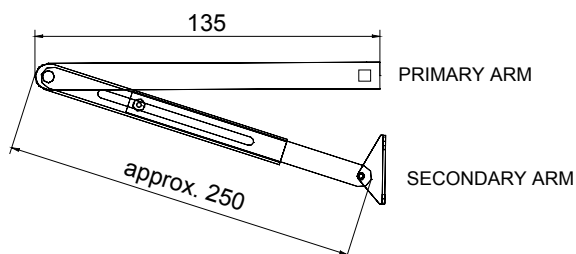
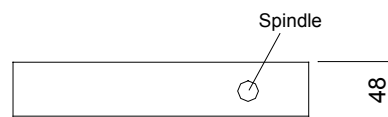
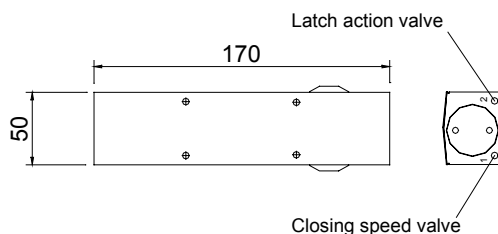

TS1500 PARALLEL ARM BRACKET

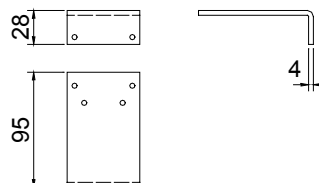

IMPORTANT WARNING:

HIGH INTERNAL PRESSURES, UNDER NO CIRCUMSTANCES ATTEMPT TO DISMANTLE THE CLOSER.

Fixing in figure 1

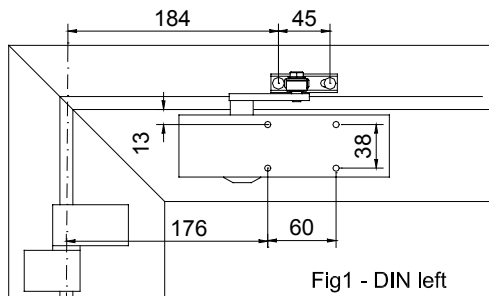
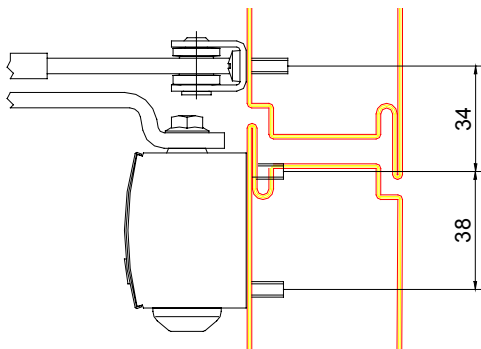

Fig1 - DIN left

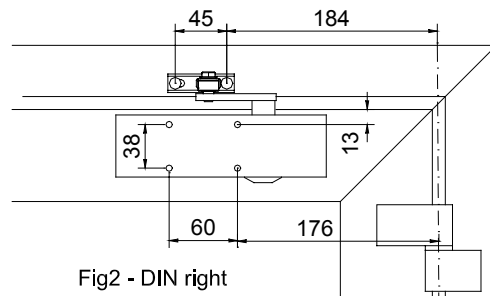

Fig2 - DIN right

➤ With the aid of the template mark out the fixing positions. Align the hinge point of the template with the centre line of the hinge on the door. (This applies to both left and right-hand doors.) There are two holes to be drilled/tapped on the transom for the arm shoe and four holes to be drilled/tapped on the door leaf for the closer body. If the template is not used refer to fixing dimensions (see figure 1 and 2 above.)

➤ Secure closer body with screws provided, making sure that the spindle is positioned towards the hinge side. (See figure 1 and 2 above.) The power size (closing force) of the **TS1500** is variable in two sizes. Each size is achieved by simply turning the power shoe 180° for the link arm. "WEAK" closing force for leaf widths up to 950mm (size 3 to EN 1154) "STRONG" closing force for leaf widths up to 1100mm (size 4 to EN 1154)

➤ If latch action is required (to overcome a latch or seals.) This can be adjusted using adjustment Valve 2 on the end of the body of the closer. Clockwise decrease latch action and anticlockwise to increase latch action. **Do not overtighten.**

➤ The closing speed can now be adjusted using the adjustment Valve 1 located on the end of the body of the closer. Clockwise will decrease the closing speed and anticlockwise will increase the closing speed. **Do not overtighten.**

➤ Test installation by simulating persons using the entrance. The door should close smoothly without slamming and present no potential hazard to traffic.

➤ When commissioning is complete push on the black plastic spindle cover cap and clip on front cover.

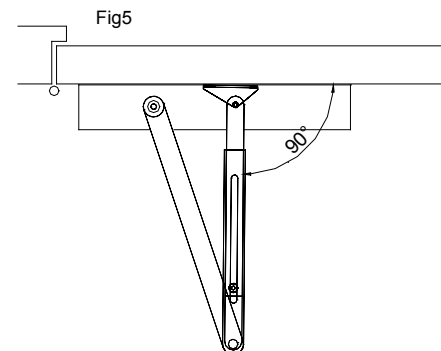
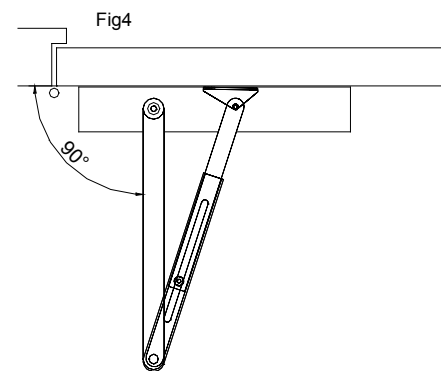
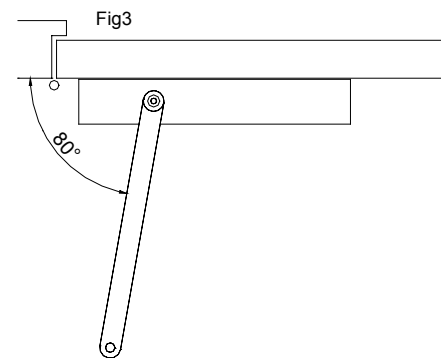

Fixing in figure 61

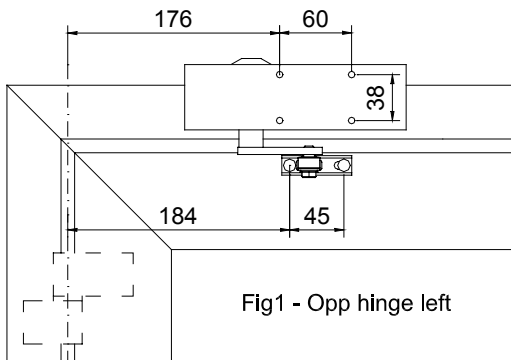
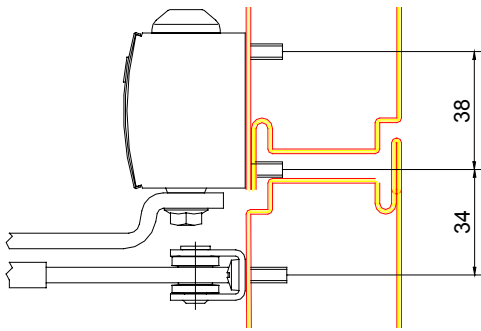
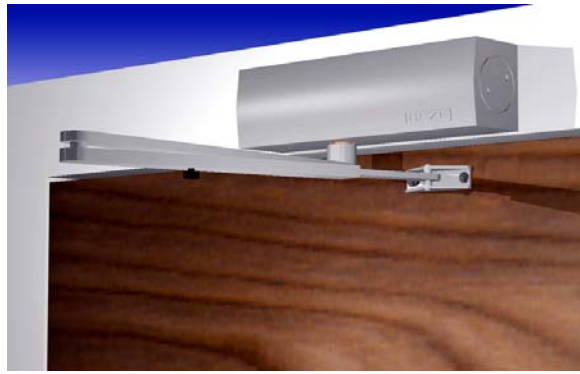

Fig1 - Opp hinge left

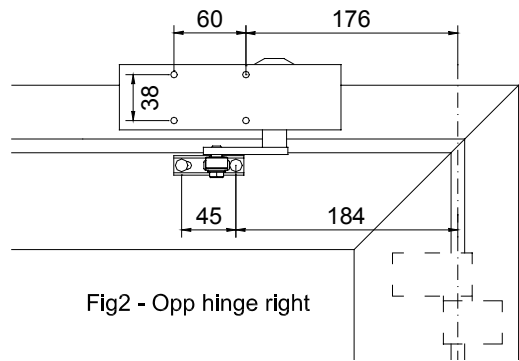

Fig2 - Opp hinge right

➤ With the aid of the template mark out the fixing positions. Align the hinge point of the template with the centre line of the hinge on the door. (This applies to both left and right-hand doors.) There are two holes to be drilled/tapped on the door leaf for the arm shoe and four holes to be drilled/tapped on the transom for the closer body. If the template is not used refer to fixing dimensions (see figure 1 and 2 above.)

➤ Secure closer body with screws provided, making sure that the spindle is positioned towards the hinge side. (See figure 1 and 2 above.) The power size (closing force) of the **TS1500** is variable in two sizes. Each size is achieved by simply turning the power shoe for the link arm. "WEAK" closing force for leaf widths up to 950mm (size 3 to EN 1154) "STRONG" closing force for leaf widths up to 1100mm (size 4 to EN 1154)

➤ If latch action is required (to overcome a latch or seals.) This can be adjusted using adjustment Valve 2 on the end of the body of the closer. Clockwise decrease latch action and anticlockwise to increase latch action. **Do not overtighten.**

➤ The closing speed can now be adjusted using the adjustment Valve 1 located on the end of the body of the closer. Clockwise will decrease the closing speed and anticlockwise will increase the closing speed. **Do not overtighten.**

➤ Test installation by simulating persons using the entrance. The door should close smoothly without slamming and present no potential hazard to traffic.

➤ When commissioning is complete push on the black plastic spindle cover cap and clip on front cover.

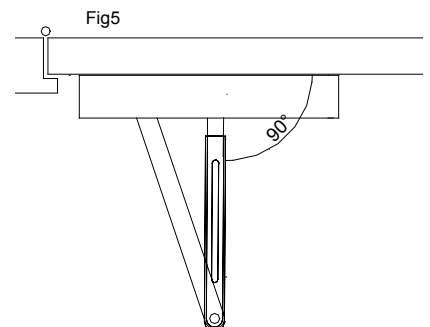
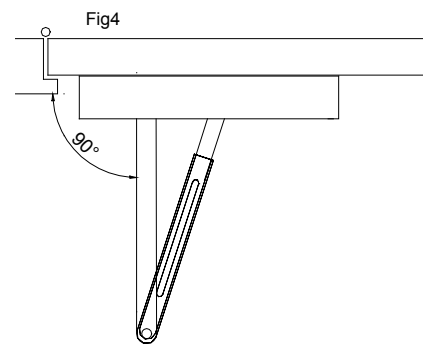
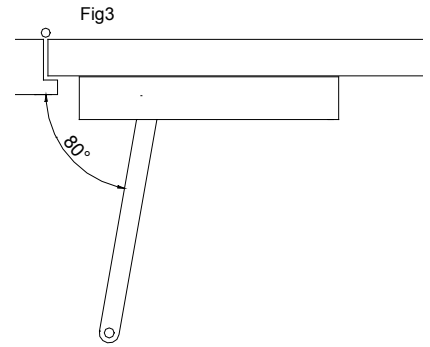

Fixing in figure 66

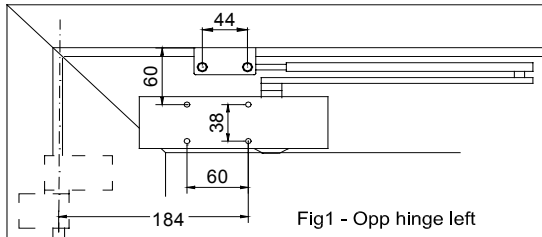
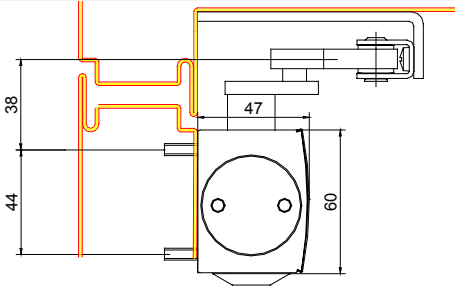

Fig1 - Opp hinge left

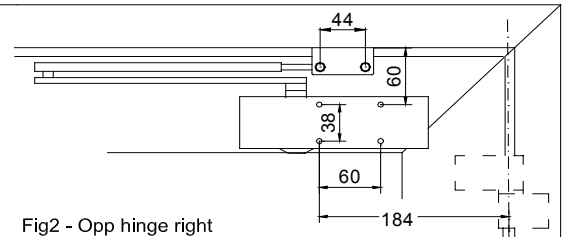
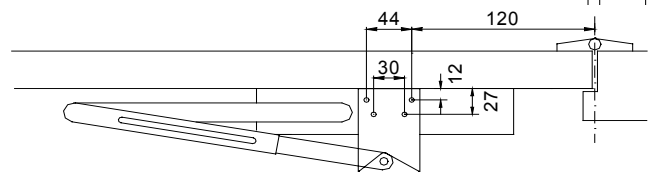
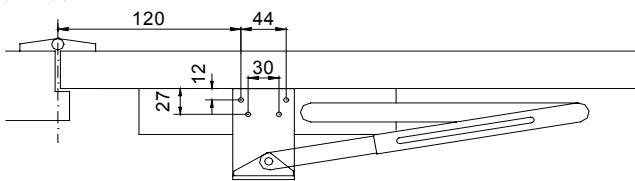

Fig2 - Opp hinge right



➤ Mark the fixing positions in accordance with fixing dimensions (see figure 1 and 2 above.) There are four holes to be drilled/tapped on the door leaf for the closer body and four holes to be drilled/tapped on the underside of the transom for the parallel arm bracket.

➤ Locate arm at approx. 10° towards the rear of the closer. (See figure 3 and 4.) Turn closing speed valve, located on the end of the body of the closer fully clockwise. This will decrease the closing speed to almost zero. **Do not overtighten.** Rotate primary arm to approximately 90° . (See figure 5 and 6.) Secure closer body to door leaf with fixings provided, making sure that the spindle is positioned away from the hinge side. (See figure 1 and 2 above.) Once body has been fitted to door increase closing speed until primary arm has come to rest. The power size (closing force) of the **TS1500** is achieved by turning the power shoe in the secondary arm.

➤ Rotate primary arm in direction of travel (away from door leaf) until an angle of approx. 2° is reached in relation to the door leaf. (See figure 7 and 8.) Tighten 10mm locking bolt on the secondary arm.

➤ If latch action is required (to overcome a latch or seals.) This can be adjusted using adjustment Valve 2 on the end of the body of the closer. Clockwise decrease latch action and anticlockwise to increase latch action. **Do not overtighten.**

➤ The closing speed can now be adjusted using the adjustment Valve 1 located on the end of the body of the closer. Clockwise will decrease the closing speed and anticlockwise will increase the closing speed. **Do not overtighten.**

➤ Test installation by simulating persons using the entrance. The door should close smoothly without slamming and present no potential hazard to traffic.

➤ When commissioning is complete push on the black plastic spindle cover cap and clip on front cover.

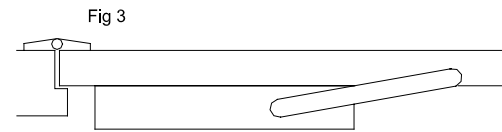

Fig 3

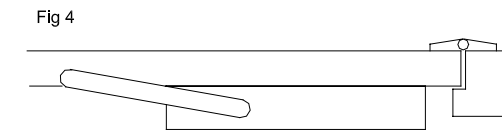

Fig 4



Fig 5

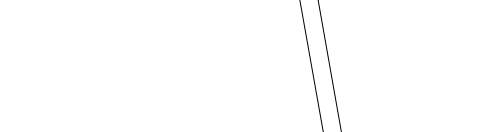

Fig 6

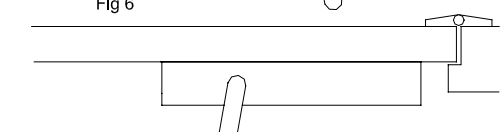

Fig 7

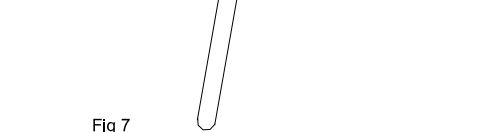

Fig 8