

GEZE TS 2000 V Overhead Door Closer



Installation Instructions

WARNING: DOOR CLOSERS WITH A POWER RATING LOWER THAN 3 OR WITH MECHANICAL HOLD OPEN DEVICES ARE NOT SUITABLE FOR USE WITH FIRE DOORS.

Components Checklist:

1x Closer body & cover	4x 5x55mm Self-tapping countersunk screws
1x Guide Rail Assembly	2x M5x40mm Countersunk screws
	4x M5x55mm Countersunk screws
2x M6 Allen Bolts	2x 5x50 Self-tapping countersunk screws
2x Plastic end caps	
1x Plastic spindle cover	

Tools Required For Installation:

Flat head screwdriver	10mm Spanner
Posidrive screwdriver	5mm Allen key (supplied)
Power drill	M5 Tap and Tap wrench (steel door mounting)
4.2mm drill bit	
Template (supplied)	
Pencil	

User Information for Door Closers

This information must be observed. Non compliance will absolve the manufacture from any liability. The door closer must only be used in accordance with its intended use; i.e. closing of side hung doors following manual opening.

Incorrect use may cause injury

- Obstruction of closing process (e.g. dragging doors, sticking weather strips/sealing rubbers, rough-running locks)
- Incorrect installation and adjustment (e.g. slamming doors)
- Danger of finger trap between frame and door leaf.
- Wrong size door closer.
- Closer used for other purpose than to close side hung doors.

Maintenance:

NOTE:

- Maintenance to be carried out by a specialist only.
- Check assembly for tolerance and undue wear.
- Tighten any screws that may have become loose.

At least once a year:

- Grease moveable parts.
- Check operation of doors and adjust if necessary.
- For door closers subject to release by Electro Mechanical and Electro Hydraulic means ensure that local regulation are adhered to.

Installation and adjustment by specialist only

Where necessary, an additional doorstop or buffer must be fitted to limit the maximum opening of the door. This is of particular relevance for slide rail closers where the opening angle may be limited by frame. For further explanations see catalogue preface and product information.

Door handing - DIN left / right

Stand facing the door on the hinge side / pull side. If the hinge or pivot is to your right hand side the door is considered to be DIN right. If the hinge or pivot is to your left hand side the door is considered to be DIN left.

TS2000 BODY

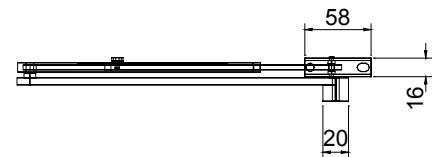
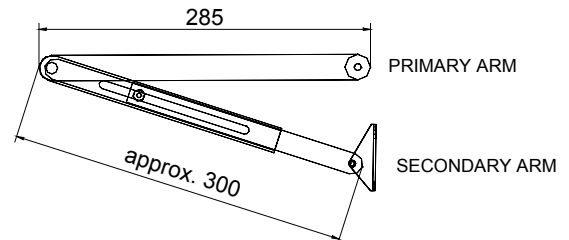
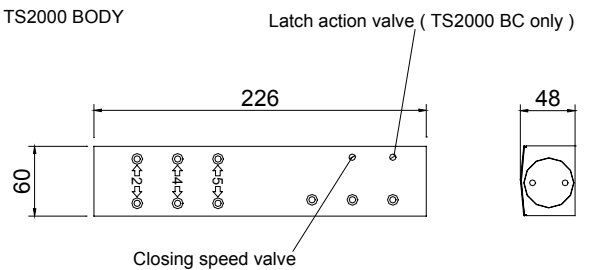

TS2000 PARALLEL ARM BRACKET

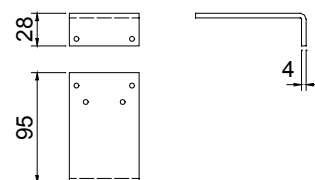

IMPORTANT WARNING:

HIGH INTERNAL PRESSURES, UNDER NO CIRCUMSTANCES ATTEMPT TO DISMANTLE THE CLOSER.

Fixing in figure 1

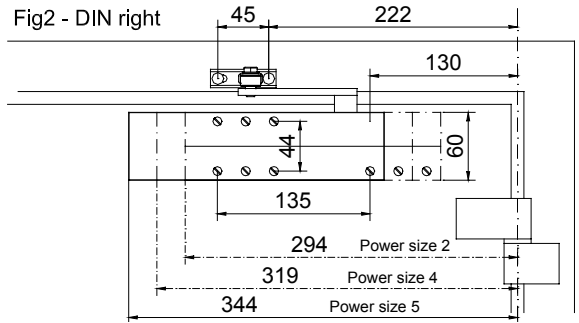
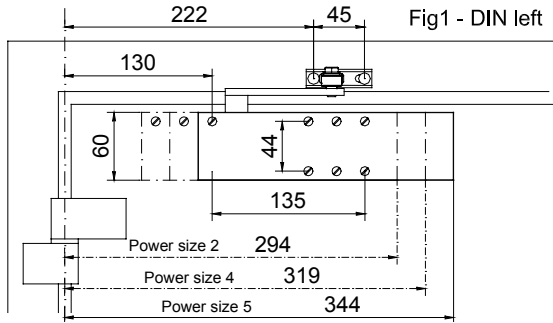
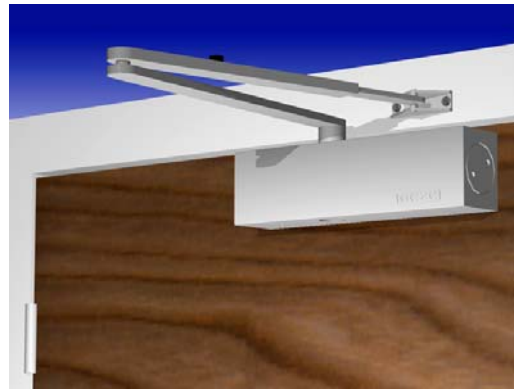
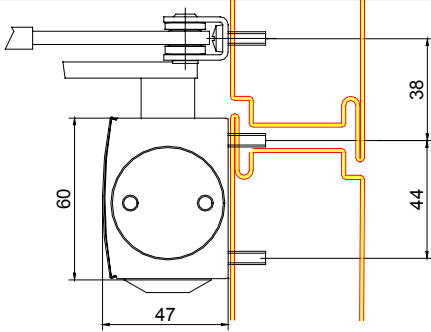

➤ With the aid of the template mark out the fixing positions. Align the hinge point of the template with the centre line of the hinge on the door. (This applies to both left and right-hand doors.) There are two holes to be drilled/tapped on the transom for the arm shoe and three holes to be drilled/tapped on the door leaf for the closer body. If the template is not used refer to fixing dimensions (see figure 1 and 2 above.)

➤ Secure closer body with screws provided, making sure that the spindle is positioned towards the hinge side. (See figure 1 and 2 above.) The power size (closing force) of the TS2000 is adjusted by moving the body of the closer either towards or away from the hinge point. The three holes that have been drilled for the closer body relate to three of the nine fixing holes on the closer. In order to fit the closer to a specific power size simply select the correct fixing holes as indicated on the body of the closer and fit.

➤ **TS2000 only. For TS2000 BC see below.** If latch action is required (to overcome a latch or seals.) Separate the primary and secondary arms. This can be done using a screwdriver as a lever. The arm sections will snap together and apart. Secure the primary arm to the spindle using M6 allen bolt supplied. Ensure splines are interlocked. Locate arm at approx. 80° with respect to the door leaf, towards the hinge point. (See figure 3.) Fix the secondary arm to the transom using the screws provided and loosen 10mm locking bolt on arm. Secure primary and secondary arms together (simply click in place.) Prime the closer slightly by rotating the **primary** arm to approx. 90° with respect to the door leaf and tighten the locking bolt. (See figure 4.)

➤ **TS2000 only. For TS2000 BC see below.** If no latch action is required. As above however when priming the closer rotate the **secondary** arm to approx. 90° with respect to the door leaf and tighten the locking bolt. (See figure 5.)

➤ **TS2000 BC.** Secure the primary arm to the spindle using M6 allen bolt supplied. Ensure splines are interlocked. Locate arm at approx. 80° with respect to the door leaf, towards the hinge point. (See figure 3.) Fix the secondary arm to the transom using the screws provided and loosen 10mm locking bolt on arm. Secure primary and secondary arms together (simply click in place.) Prime the closer slightly by rotating the primary arm to approx. 90° with respect to the door leaf and tighten the locking bolt.

• The back check is a segment of the closers opening cycle with increased resistance. It is factory set to come in when the door is at approx. 80°. In order to bring this in earlier disengage the primary and secondary arms. Loosen the M6 allen bolt securing the primary arm to the closer enough to enable adjustment. Rotate the primary arm 1 notch of the splined spindle in the opposite direction to travel. Re-tighten M6 allen bolt securing the primary arm to the closer body. Loosen 10mm locking bolt on secondary arm and re-connect primary and secondary arms. Prime the closer by rotating the primary arm to approx. 90° with respect to the door leaf and tighten the 10mm locking bolt. If on testing the back check is still not early enough repeat above until adjusted satisfactorily.

• The latch action of the TS2000 BC can now be adjusted using the adjustment valve located on the front of the body of the closer next to the closing speed adjustment valve. Clockwise will decrease the latch action and anticlockwise will increase the latch action. **Do not overtighten.**

➤ The closing speed can now be adjusted using the adjustment valve located on the front of the body of the closer. Clockwise will decrease the closing speed and anticlockwise will increase the closing speed. **Do not overtighten.**

➤ Test installation by simulating persons using the entrance. The door should close smoothly without slamming and present no potential hazard to traffic.

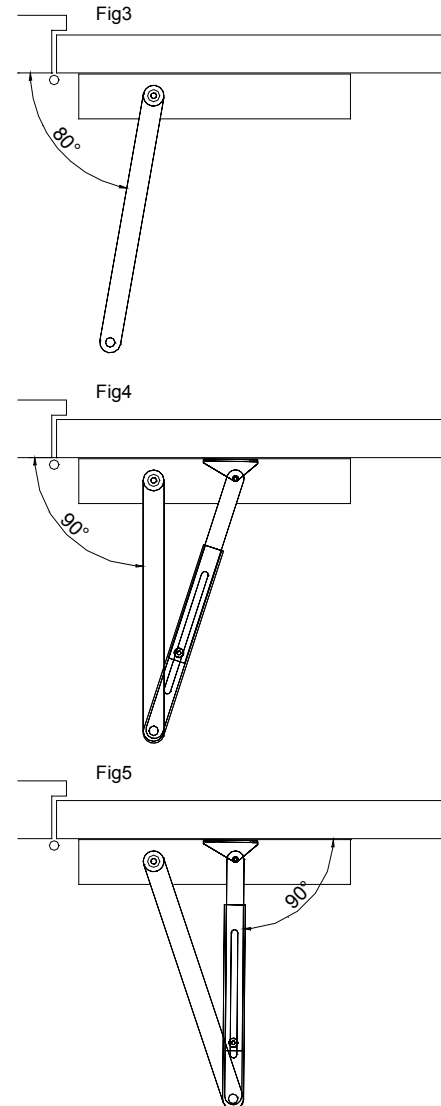

Fixing in figure 61

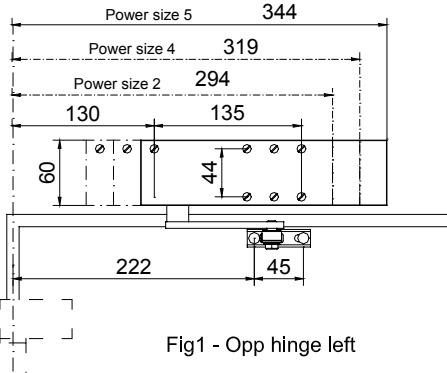
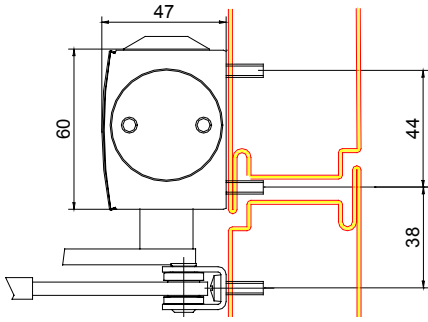
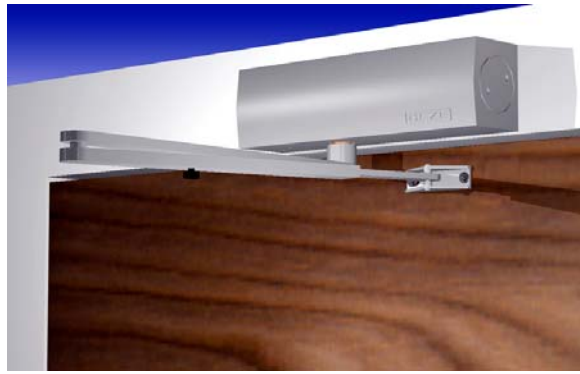

Fig1 - Opp hinge left

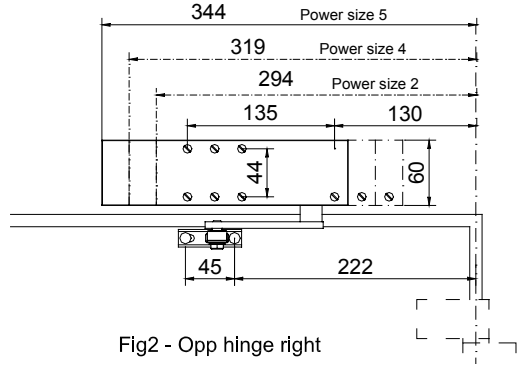

Fig2 - Opp hinge right

>With the aid of the template mark out the fixing positions. Align the hinge point of the template with the centre line of the hinge on the door. (This applies to both left and right-hand doors.) There are two holes to be drilled/tapped on the door leaf for the arm shoe and three holes to be drilled/tapped on the transom for the closer body. If the template is not used refer to fixing dimensions (see figure 1 and 2 above.)

>Secure closer body with screws provided, making sure that the spindle is positioned towards the hinge side. (See figure 1 and 2 above.) The power size (closing force) of the TS2000 is adjusted by moving the body of the closer either towards or away from the hinge point. The three holes that have been drilled for the closer body relate to three of the nine fixing holes on the closer. In order to fit the closer to a specific power size simply select the correct fixing holes as indicated on the body of the closer and fit.

>**TS2000 only. For TS2000 BC see below.** If latch action is required (to overcome a latch or seals.) Separate the primary and secondary arms. This can be done using a screwdriver as a lever. The arm sections will snap together and apart. Secure the primary arm to the spindle using M6 allen bolt supplied. Ensure splines are interlocked. Locate arm at approx. 80° with respect to the transom, towards the hinge point. (See figure 3.) Fix the secondary arm to the door leaf using the screws provided and loosen 10mm locking bolt on arm. Secure primary and secondary arms together (simply click in place.) Prime the closer slightly by rotating the **primary** arm to approx. 90° with respect to the door leaf and tighten the locking bolt. (See figure 4.)

>**TS2000 only. For TS2000 BC see below.** If no latch action is required. As above however when priming the closer rotate the **secondary** arm to approx. 90° with respect to the door leaf and tighten the locking bolt. (See figure 5.)

>**TS2000 BC.** Secure the primary arm to the spindle using M6 allen bolt supplied. Ensure splines are interlocked. Locate arm at approx. 80° with respect to the transom, towards the hinge point. (See figure 3.) Fix the secondary arm to the door leaf using the screws provided and loosen 10mm locking bolt on arm. Secure primary and secondary arms together (simply click in place.) Prime the closer slightly by rotating the primary arm to approx. 90° with respect to the door leaf and tighten the locking bolt.

- The back check is a segment of the closers opening cycle with increased resistance. It is factory set to come in when the door is at approx. 80°. In order to bring this in earlier disengage the primary and secondary arms. Loosen the M6 allen bolt securing the primary arm to the closer enough to enable adjustment. Rotate the primary arm 1 notch of the splined spindle in the opposite direction to travel. Re-tighten M6 allen bolt securing the primary arm to the closer body. Loosen 10mm locking bolt on secondary arm and re-connect primary and secondary arms. Prime the closer by rotating the primary arm to approx. 90° with respect to the door leaf and tighten the 10mm locking bolt. If on testing the back check is still not early enough repeat above until adjusted satisfactorily.

- The latch action of the TS2000 BC can now be adjusted using the adjustment valve located on the front of the body of the closer next to the closing speed adjustment valve. Clockwise will decrease the latch action and anticlockwise will increase the latch action. **Do not overtighten.**

>The closing speed can now be adjusted using the adjustment valve located on the front of the body of the closer. Clockwise will decrease the closing speed and anticlockwise will increase the closing speed. **Do not overtighten.**

>Test installation by simulating persons using the entrance. The door should close smoothly without slamming and present no potential hazard to traffic.

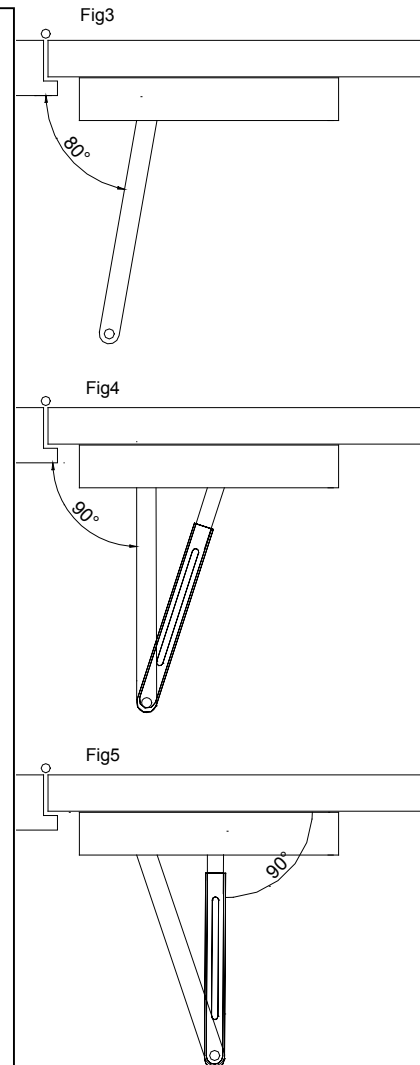

Fixing in figure 66

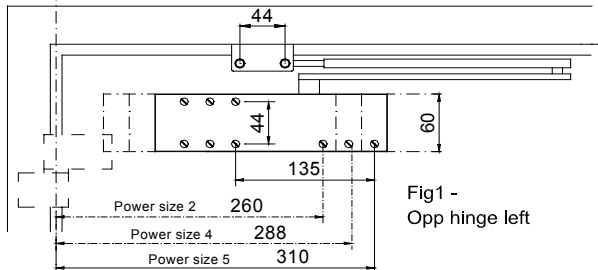
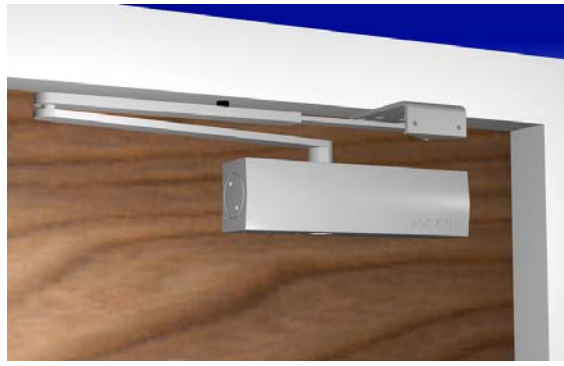
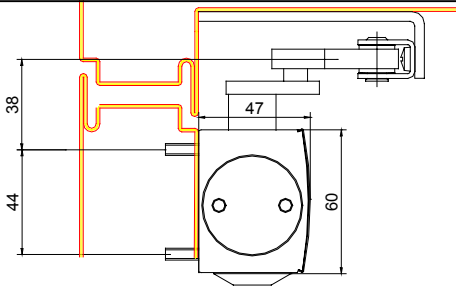

Fig1 - Opp hinge left

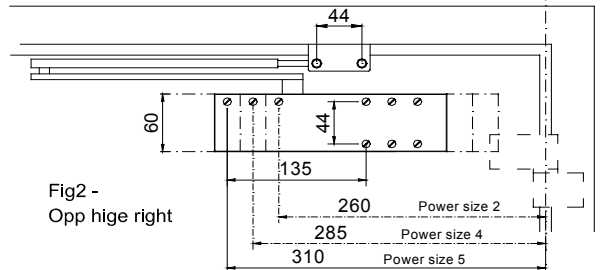

Fig2 - Opp hinge right

➤ Mark the fixing positions in accordance with fixing dimensions (see figure 1 and 2 above.) There are three holes to be drilled/tapped on the door leaf for the closer body and four holes to be drilled/tapped on the underside of the transom for the parallel arm bracket.

➤ Separate the primary and secondary arms. This can be done using a screwdriver as a lever. The arm sections will snap together and apart. Secure the primary arm to the spindle using M6 allen bolt supplied. Ensure splines are interlocked. Locate arm at approx. 10° towards the rear of the closer. (See figure 3 and 4.) Turn closing speed valve, located on the front of the body of the closer fully clockwise. This will decrease the closing speed to almost zero. Do not overtighten. Rotate primary arm to approximately 90°. (See figure 5 and 6.) Secure closer body to door leaf with fixings provided, making sure that the spindle is positioned away from the hinge side. (See figure 1 and 2 above.) The power size (closing force) of the TS2000 is not adjustable in this configuration and the unit must be mounted using the centre fixing holes. Secure primary and secondary arms together (simply click in place.)

➤ Rotate primary arm in direction of travel (away from door leaf) until an angle of approx. 2° is reached in relation to the door leaf. (See figure 7 and 8.) Tighten 10mm locking bolt.

➤ **TS2000 only. For TS2000 BC see below.** If latch action is required (to overcome a latch or seals) fit closer as described above.

➤ **TS2000 only. For TS2000 BC see below.** If no latch action is required. Fit closer as described above. Separate the primary and secondary arms. Turn closing speed valve, located on the front of the body of the closer fully clockwise. This will decrease the closing speed to almost zero. Do not overtighten. Rotate the primary arm approx. 90° in the direction of travel (roughly perpendicular to the door leaf.) Loosen the M6 allen bolt securing the primary arm to the closer body enough to enable adjustment. Rotate the primary arm 1 notch of the splined spindle in the opposite direction of travel. Re-tighten M6 allen bolt securing the primary arm to the closer body. Loosen 10mm locking bolt on secondary arm and re-connect primary and secondary arms. Re-adjust the closing speed. Rotate primary arm in direction of travel (away from door leaf) until an angle of approx. 2° is reached in relation to the door leaf. (See figure 7 and 8.) Tighten the 10mm locking bolt. If on testing the latch action has not been removed repeat above until adjusted satisfactorily.

➤ **TS2000 BC.** Note: If backcheck is required to come in at any opening angle less than 100° then latch action is not possible with this unit.

• The back check is a segment of the closers opening cycle with increased resistance. In this configuration it is factory set to come in when the door is at approx. 100°. In order to bring this in earlier fit closer as described above. Separate the primary and secondary arms. Turn closing speed valve, located on the front of the body of the closer fully clockwise. This will decrease the closing speed to almost zero. Do not overtighten. Rotate the primary arm approx. 90° in the direction of travel (roughly perpendicular to the door leaf.) Loosen the M6 allen bolt securing the primary arm to the closer body enough to enable adjustment. Rotate the primary arm 1 notch of the splined spindle in the opposite direction of travel. Re-tighten M6 allen bolt securing the primary arm to the closer body. Loosen 10mm locking bolt on secondary arm and re-connect primary and secondary arms. Re-adjust the closing speed. Rotate primary arm in direction of travel (away from door leaf) until an angle of approx. 2° is reached in relation to the door leaf. (See figure 5 and 6.) Tighten the 10mm locking bolt. If on testing the back check is still not early enough repeat above until adjusted satisfactorily

• If the unit has not been adjusted to bring the backcheck in earlier then the latch action of the TS2000 BC can now be adjusted using the adjustment valve located on the front of the body of the closer next to the closing speed adjustment valve. Clockwise will decrease the latch action and anticlockwise will increase the latch action. **Do not overtighten.**

➤ The closing speed can now be adjusted using the adjustment valve located on the front of the body of the closer. Clockwise will decrease the closing speed and anticlockwise will increase the closing speed. **Do not overtighten.**

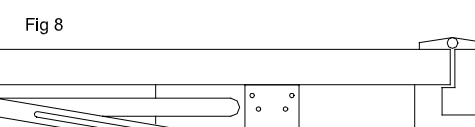
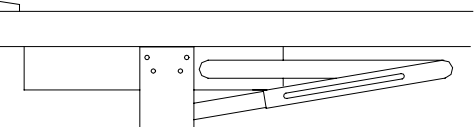
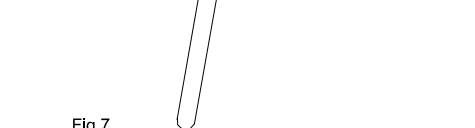
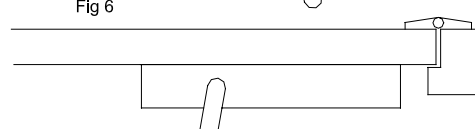
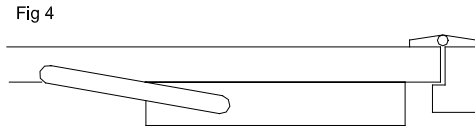
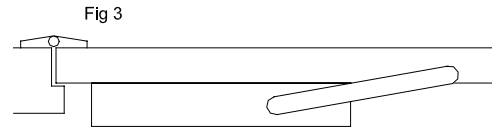



M5

Ident.-Nr. 013470 Änd.-St. 1
Zeichng.-Nr. 20514/9-963

GEZE

TS 2000 V BC

Öffnungsdämpfung fix

fixed back-check

Amortissement

à l'ouverture fixe

ammortizzazione

apertura di tipo fisso

Amortiguación

de apertura rápida

M5



a = lower arm part at right angle to
door
for this position.

by a

drill jig.

Adjustment of upper arm part:

See illustration.

B = Closing speed adjustment

Setting of the closing speed as per DIN
18 263 and „IFBT“ guide lines (closing
time 5 secs. from 90° open position).

E = Latch action adjustment

Check smooth opening and closing of the
door.

be

oor

ndi-

lease

sizes

Maintenance, care, repairs

Regular maintenance is necessary (see user
information). It must be performed by an expert
company. The installer must draw the user's
attention to this fact.

Repairs or maintenance only to be carried out by
GEZE or their approved installers.

The installer must hand the mounting instruction
and the user information (enclosed slip) over to
the system operator.

er size

2

3

4

