



TS4000/DA Series Overhead Door Closer

Installation Instructions

WARNING: DOOR CLOSERS WITH A POWER RATING LOWER THAN 3 OR WITH MECHANICAL HOLD OPEN DEVICES ARE NOT SUITABLE FOR USE WITH FIRE DOORS.

Components Checklist:

- 1 x Closer body and cover
- 1 x Arm assembly
- 1 x M6 Allen bolt
- 4 x M5 x 20mm Pan head screws
- 1 x Plastic spindle cover
- 4 x 5 x 55mm Self-tapping countersunk screws
- 4 x M5 x 55mm Countersunk screws
- 1 x Adjustment screw (fitted to arm)

Tools Required For Installation:

- Flat head screwdriver
- Posidrive screwdriver
- Power drill
- 4.2mm drill bit
- Template (supplied)
- Pencil
- 10mm Spanner
- 5mm Allen key (supplied)
- M5 Tap and Tap wrench (steel door mounting)

User Information for Door Closers

This information must be observed. Non compliance will absolve the manufacture from any liability. The door closer must only be used in accordance with its intended use; i.e. closing of side hung doors following manual opening.

Incorrect use may cause injury

- Obstruction of closing process (e.g. dragging doors, sticking weather strips/sealing rubbers, rough-running locks)
- Incorrect installation and adjustment (e.g. slamming doors)
- Danger of finger trap between frame and door leaf.
- Wrong size door closer.
- Closer used for other purpose than to close side hung doors.

Maintenance:

NOTE:

- Maintenance to be carried out by a specialist only.
- Check assembly for tolerance and undue wear.
- Tighten any screws that may have become loose.

At least once a year:

- Grease moveable parts.
- Check operation of doors and adjust if necessary.
- For door closers subject to release by Electro Mechanical and Electro Hydraulic means ensure that local regulation are adhered to.

Installation and adjustment by specialist only

Where necessary, an additional doorstop or buffer must be fitted to limit the maximum opening of the door. This is of particular relevance for slide rail closers where the opening angle may be limited by frame. For further explanations see catalogue preface and product information.

Door handing - DIN left / right

Stand facing the door on the hinge / pull side. If the hinge or pivot is to your right hand side the door is considered to be DIN right. If the hinge or pivot is to your left-hand side the door is considered to be DIN left.

IMPORTANT WARNING:

HIGH INTERNAL PRESSURES, UNDER NO CIRCUMSTANCES ATTEMPT TO DISMANTLE THE CLOSER.

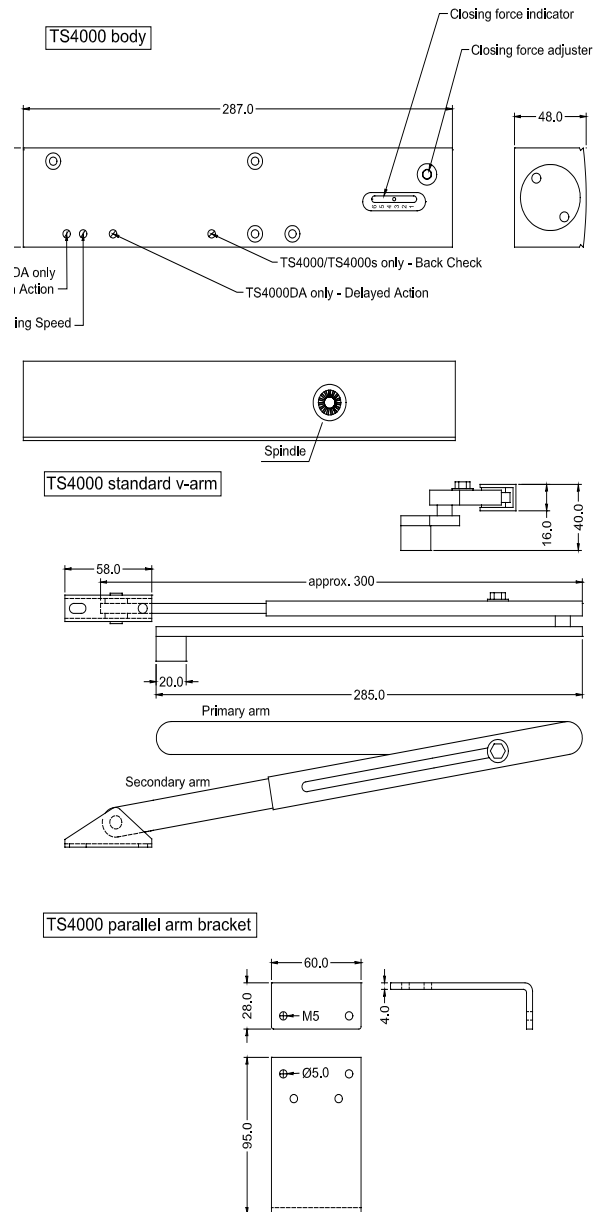

Fixing in figure 1

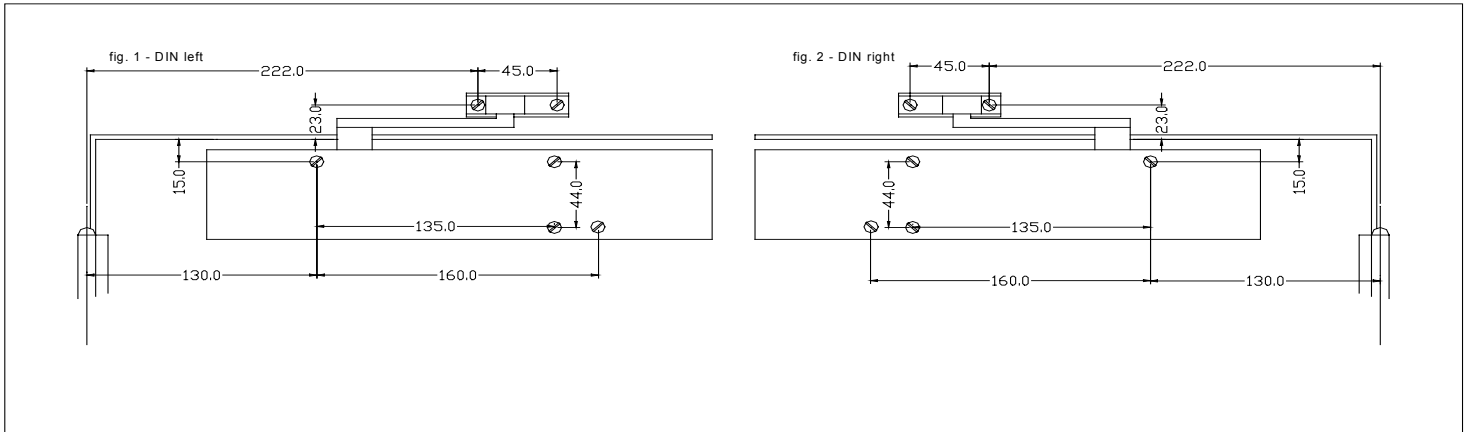
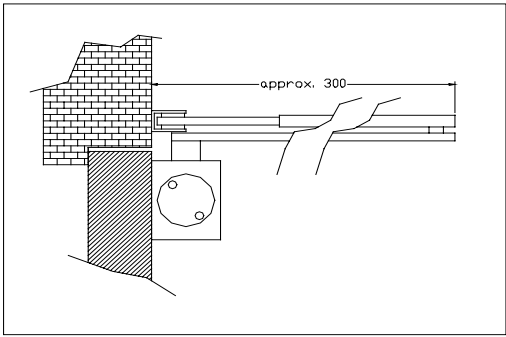

- With the aid of the template mark out the fixing positions. Align the hinge point of the template with the centre line of the hinge on the door. (This applies to both left and right-hand doors.) There are two holes to be drilled/tapped on the transom for the arm shoe and four holes to be drilled/tapped on the door leaf for the closer body. If the template is not used refer to fixing dimensions (see figure 1 and 2 above.)
- Secure closer body with screws provided, making sure that the spindle is positioned towards the hinge side. (See figure 1 and 2 above.) The power size (closing force) of the TS4000 is adjusted by turning the Allen key screw situated above and to the right of the clear glass indicator tube containing a small ball bearing. As the screw is turned the ball bearing will gradually move to show its power size. If it doesn't appear to be moving give the indicator a gentle tap with your finger which will release it. (Please be aware that the power sizes indicated on the closer are EN ratings 1 – 6.)
- **TS4000 for TS4000DA see below** If latch action is required (to overcome a latch or seals.) Separate the primary and secondary arms. This can be done using a screwdriver as a lever between the knuckle. The arm sections will snap together and apart. Secure the primary arm to the spindle using M6 allen bolt supplied. Ensure splines are interlocked. Locate arm at approx. 80° with respect to the door leaf, towards the hinge point. (See figure 3.) Fix the secondary arm to the transom using the screws provided and loosen 10mm locking bolt on arm. Secure primary and secondary arms together (simply click in place.) Prime the closer slightly by rotating the **primary** arm to approx. 90° with respect to the door leaf and tighten the locking bolt. (See figure 4.)
- **TS4000 for TS4000DA see below.** If no latch action is required. As above however when priming the closer rotate the **secondary** arm to approx. 90° with respect to the door leaf and tighten the locking bolt. (See figure 5.)
- The latch action of the TS4000DA can now be adjusted using the adjustment valve located on the front in the centre of the body. Clockwise will decrease the latch action and anticlockwise will increase the latch action. **Do not overtighten.**
- TS4000 for TS4000DA see below. The back check is a segment of the closers opening cycle with increased resistance. It is factory set to come in when the door is at approx. 80°. To bring the back check in later turn the valve anticlockwise.
- TS4000DA There is No back check adjustment on the TS4000DA it is fixed to come in at 80°.
- TS4000DA. A valve on the front of the closer varies delayed action. It can delay the closing of the door from 0 – 30 seconds. Clockwise gives a shorter delayed action, anticlockwise gives a longer delayed action. **Do not overtighten.**
- The closing speed can now be adjusted using the adjustment valve located on the front of the body of the closer. Clockwise will decrease the closing speed and anticlockwise will increase the closing speed. **Do not overtighten.**

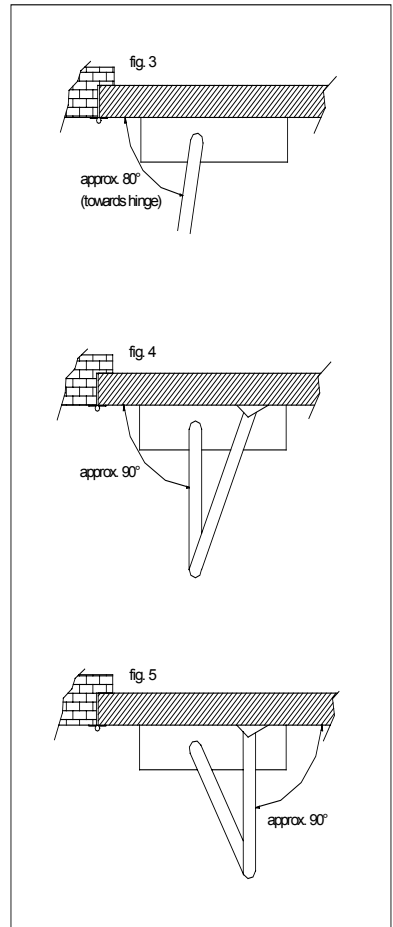

Fixing in figure 61

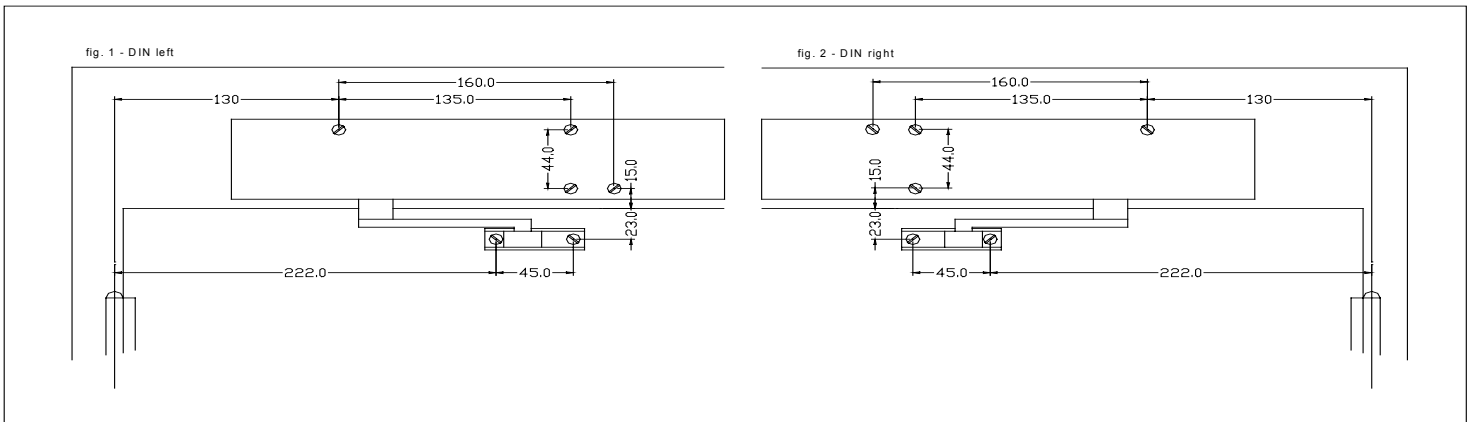
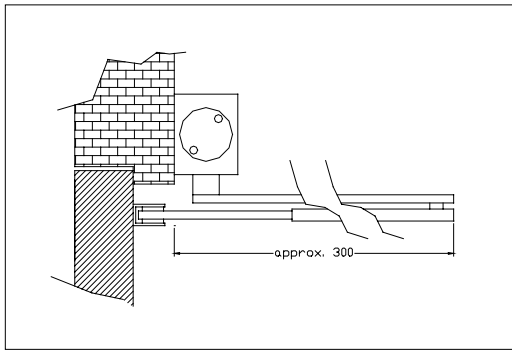

- With the aid of the template mark out the fixing positions. Align the hinge point of the template with the centre line of the hinge on the door. (This applies to both left and right-hand doors.) There are two holes to be drilled/tapped on the door leaf for the arm shoe and three holes to be drilled/tapped on the transom for the closer body. If the template is not used refer to fixing dimensions (see figure 1 and 2 above.)
- Secure closer body with screws provided, making sure that the spindle is positioned towards the hinge side. (See figure 1 and 2 above.) The power size (closing force) of the TS4000 is adjusted by turning the Allen key screw situated above and to the right of the clear glass indicator tube containing a small ball bearing. As the screw is turned the ball bearing will gradually move to show the power size. If it doesn't appear to be moving give the indicator tube a gentle tap with your finger which will then release it. (Please be aware that the power sizes indicated on the closer are EN ratings 1 – 6.)
- **TS4000 for TS4000DA see below.** If latch action is required (to overcome a latch or seals.) Separate the primary and secondary arms. This can be done using a screwdriver as a lever between the knuckle. The arm sections will snap together and apart. Secure the primary arm to the spindle using M6 Allen bolt supplied. Ensure splines are interlocked. Locate arm at approx. 80° with respect to the transom, towards the hinge point. (See figure 3.) Fix the secondary arm to the door leaf using the screws provided and loosen 10mm locking bolt on arm. Secure primary and secondary arms together (simply click in place.) Prime the closer slightly by rotating the **primary** arm to approx. 90° with respect to the door leaf and tighten the locking bolt. (See figure 4.)
- **TS4000 for TS4000DA see below.** If no latch action is required. As above however when priming the closer rotate the **secondary** arm to approx. 90° with respect to the door leaf and tighten the locking bolt. (See figure 5.)
- **The latch action of the TS4000DA can now be adjusted using the adjustment valve located on the front in the centre of the body. Clockwise will decrease the latch action and anticlockwise will increase the latch action. Do not overtighten.**
- TS4000 - The back check is a segment of the closes opening cycle with increased resistance. It is factory set to come in when the door is approx.80°. To bring the back check in later turn the valve anticlockwise.
- TS4000DA There is No back check adjustment on this model it is fixed to come in at 80°.
- TS4000DA. A valve on the front of the closer varies delayed action. It can delay the closing of the door from 0 – 30 seconds. Clockwise gives a shorter delayed action, anticlockwise gives a longer delayed action. **Do not overtighten.**
- The closing speed can now be adjusted using the adjustment valve located on the front of the body of the closer. Clockwise will decrease the closing speed and anticlockwise will increase the closing speed. **Do not overtighten.**

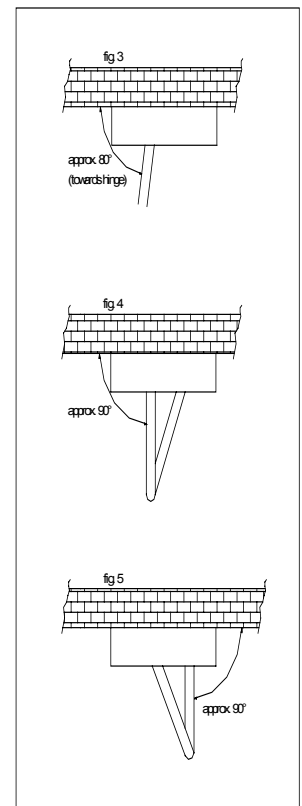

Fixing in figure 66

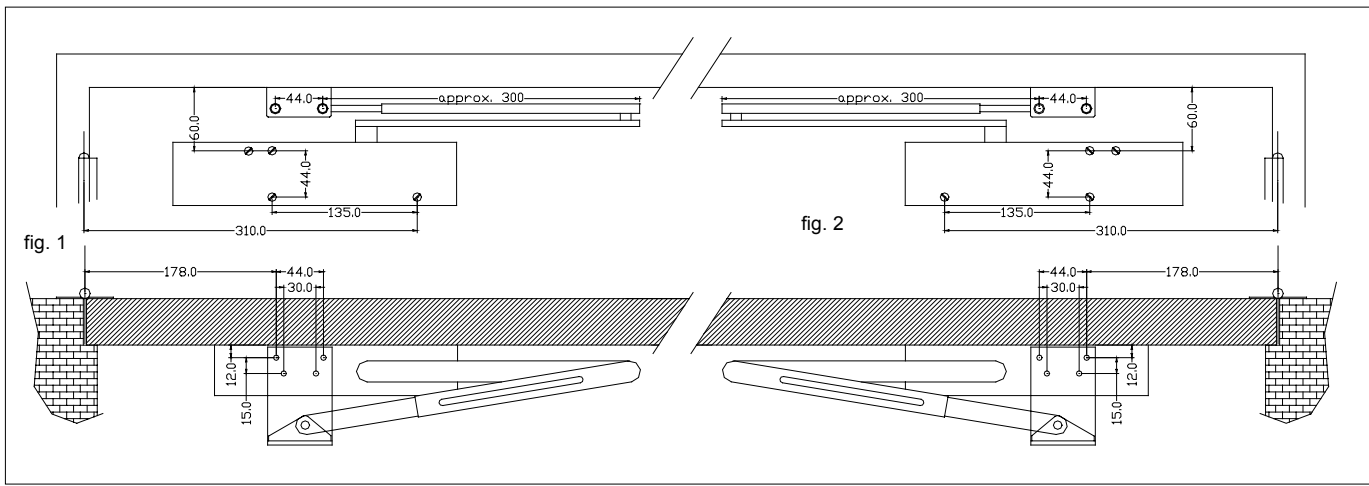
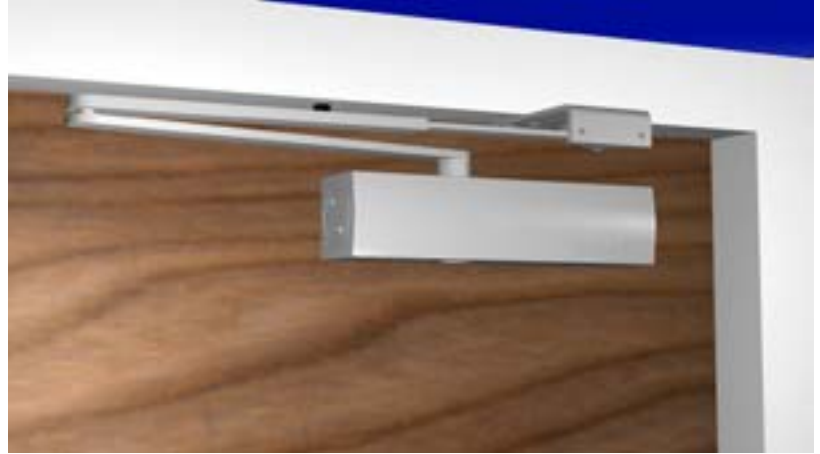
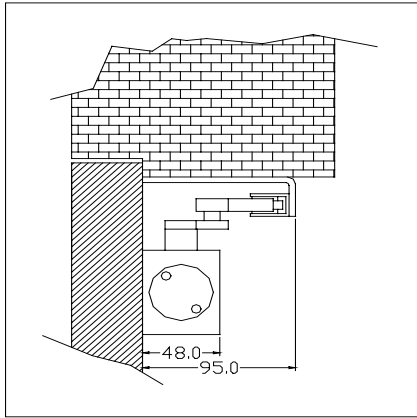

- Mark the fixing positions in accordance with fixing dimensions (see figure 1 and 2 above.) There are three holes to be drilled/tapped on the door leaf for the closer body and four holes to be drilled/tapped on the underside of the transom for the parallel arm bracket.
- Separate the primary and secondary arms. This can be done using a screwdriver as a lever. The arm sections will snap together and apart. Secure the primary arm to the spindle using M6 allen bolt supplied. Ensure splines are interlocked. Locate arm at approx. 10° towards the rear of the closer. (See figure 3 and 4.) Turn closing speed valve, located on the front of the body of the closer fully clockwise. This will decrease the closing speed to almost zero. **Do not overtighten.** Rotate primary arm to approximately 90°. (See figure 5 and 6.) Secure closer body to door leaf with fixings provided, making sure that the spindle is positioned away from the hinge side. (See figure 1 and 2 above.) The power size (closing force) of the TS2000 is not adjustable in this configuration and the unit must be mounted using the centre fixing holes. Secure primary and secondary arms together (simply click in place.)
- Rotate primary arm in direction of travel (away from door leaf) until an angle of approx. 2° is reached in relation to the door leaf. (See figure 7 and 8.) Tighten 10mm locking bolt.
- **TS4000 only.** If no latch action is required. Fit closer as described above. Separate the primary and secondary arms. Turn closing speed valve, located on the front of the body of the closer fully clockwise. This will decrease the closing speed to almost zero. **Do not overtighten.** Rotate the primary arm approx. 90° in the direction of travel (roughly perpendicular to the door leaf.) Loosen the M6 allen bolt securing the primary arm to the closer body enough to enable adjustment. Rotate the primary arm 1 notch of the splined spindle in the opposite direction of travel. Re-tighten M6 allen bolt securing the primary arm to the closer body. Loosen 10mm locking bolt on secondary arm and re-connect primary and secondary arms. Re-adjust the closing speed. Rotate primary arm in direction of travel (away from door leaf) until an angle of approx. 2° is reached in relation to the door leaf. (See figure 7 and 8.) Tighten the 10mm locking bolt. If on testing the latch action has not been removed repeat above until adjusted satisfactorily.
- **The latch action of the TS4000DA can now be adjusted using the adjustment valve located on the front in the centre of the body. Clockwise will decrease the latch action and anticlockwise will increase the latch action. Do not overtighten.**
- TS4000DA There is No back check adjustment on this model it is fixed to come in at 80°.
- TS4000DA. A valve on the front of the closer varies delayed action. It can delay the closing of the door from 0 – 30 seconds. Clockwise gives a shorter delayed action, anticlockwise gives a longer delayed action. **Do not overtighten.**
- The closing speed can now be adjusted using the adjustment valve located on the front of the body of the closer. Clockwise will decrease the closing speed and anticlockwise will increase the closing speed. **Do not overtighten.**
- Test installation by simulating persons using the entrance. The door should close smoothly without slamming and present no potential hazard to traffic.
- When commissioning is complete push on the black plastic spindle cover cap and clip on front cover.

