

OPTION 1 - WITH SOFFIT ANGLE BRACKET

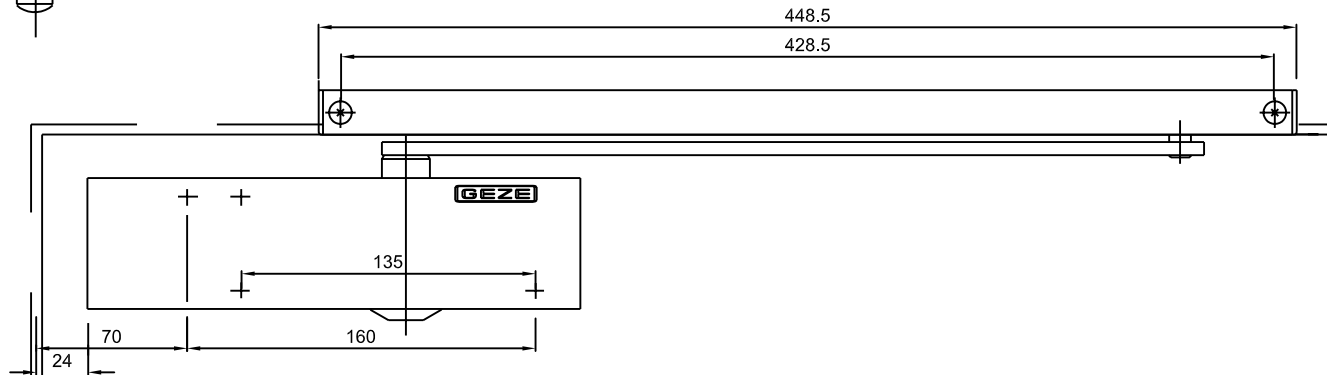

OPTION 2 - WITHOUT SOFFIT ANGLE BRACKET
FOR FLUSH OVERPANEL OR MAX REVEAL 20mm

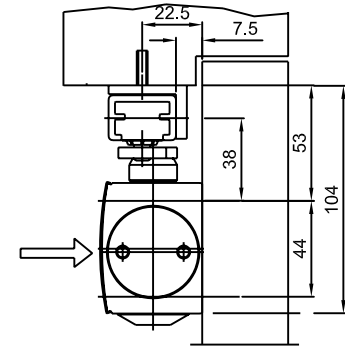
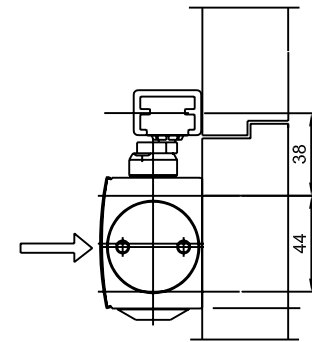

This drawing shows the actual stage of product development at the date indicated.
No claims or damages in any form can be made against GEZE as a result of the interpretation of this drawing. This drawing remains the property of GEZE and is made available to third parties only for the duration of contractual obligations. All rights connected with this drawing remain in possession of GEZE. This drawing may not be copied or handed over to third parties without the express consent of GEZE.

Specification					
Project					
SB	A	-----			
Drawn	Rev	Date	Reason for change		
Drawing No.		App'd	Scale	Date	
TBUK/BAU/T3Fig 6		--	NTS	04.02.04	
Title					
TS3000V FIGURE 6					



GEZE UK Ltd
 Blenheim Way
 Fradley Park
 Lichfield
 STAFFORDSHIRE
 WS13 8SX
 TEL +44 (0)1543 44 30 00
 FAX +44 (0)1543 44 30 01 www.geze.com