

TIWI Fitting Instructions

Bottom Rolling External Folding Door System.



Specifications;

Maximum Leaf Width: 900mm
 Maximum Leaf Height: 2700mm
 Maximum Leaf Weight: 70Kg's

1 Ensure you have selected the correct hardware for your door layout - See below;

Kits can be combined
 (i.e. 1x3D with 1x2D)



Kits can be combined
 (i.e. 1x3D with 1x2D)

2 Joinery Details - Ensure your doors are made to the correct size for the opening using the following calculations;

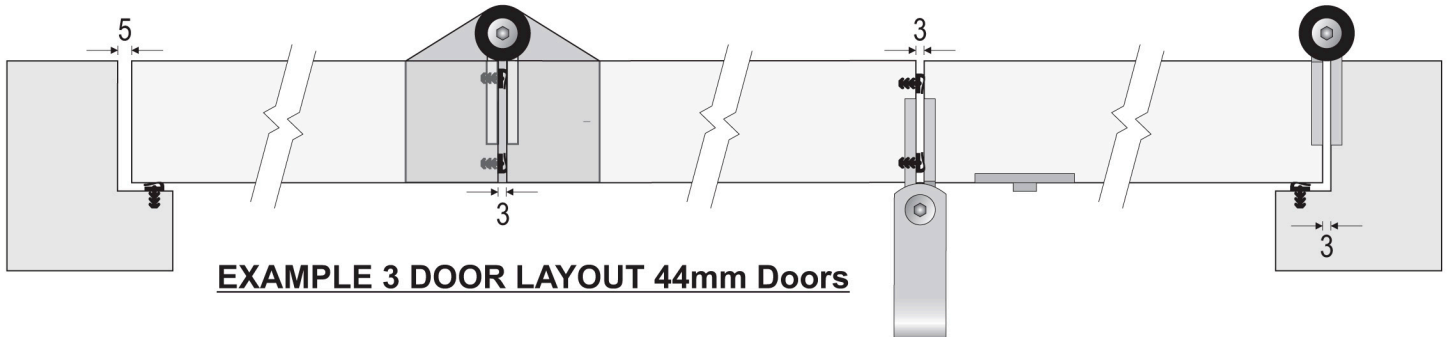

Total gaps = 5mm + 3mm + 3mm + 3mm = 14mm
 Total width of opening = 2700mm
 2700mm - 14mm = 2686mm
 Each leaf Width = 2686mm ÷ 3 = 895mm per leaf

Amend formula according to your layout. Use the chart below for even leaf clearance between leading leaf and closing jamb. You also need to allow for treatment or painting when calculating these gaps.

Please note that the last leaf of a even leaf system must be 12mm longer. Please factor this into the above formula by deducting 12mm (or 24mm if 2+2 or 4+4) from total width of opening between jambs and then add 12mm to the last leaf (or 24mm for meeting leaves).

Door Thickness mm	Leaf Width mm						
	500	600	700	800	900	1000	
44	10mm	9mm	8mm	7mm	6mm	5mm	
56	9mm	8mm	7mm	6mm	5mm	5mm	

Note: If gap is over 7mm wide then we recommend that 2 seals be used closing on each other.

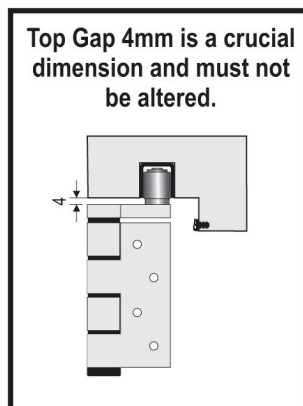
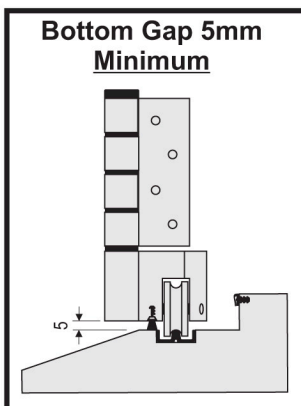

For the height of the leaves the total gap should be a minimum of 9mm - see diagrams;

Therefore formula is;

Height of opening - Total gaps = Door height.

3

Leaf Preparation - Below are the details of where hardware fits and all required cut outs on the leaves of the system;

3 Door Layout (56mm)

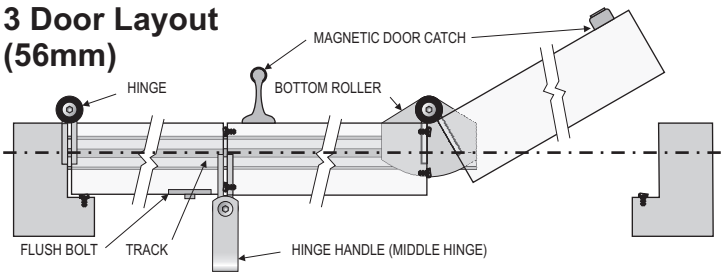

Top guides are always above bottom rollers.

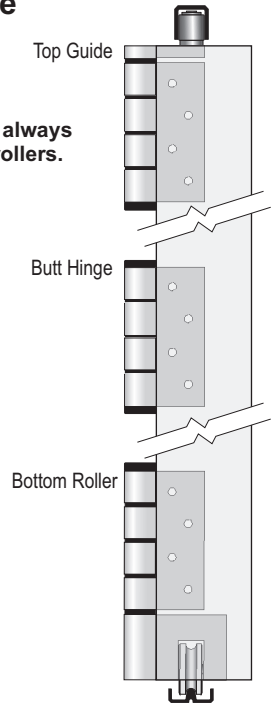

End View (56mm)

4 Door Layout (44mm)

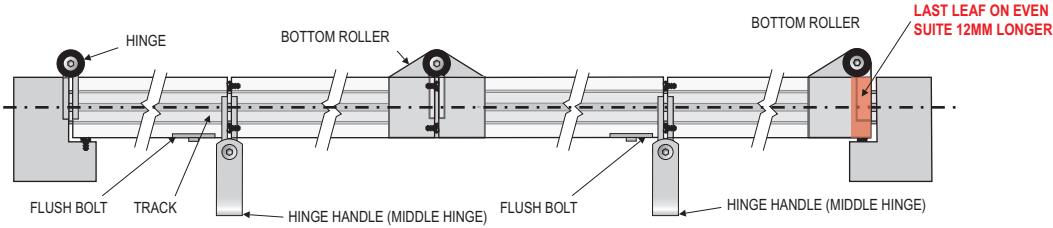

1) Cut out details for the bottom rollers.

CAUTION: Please note the 2 different bottom roller sizes available and use correct detail.

866x4 Bottom Roller - 44mm

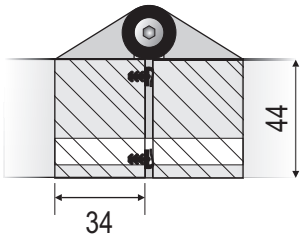

866x4 ROLI / LORI Bottom Roller - 44mm

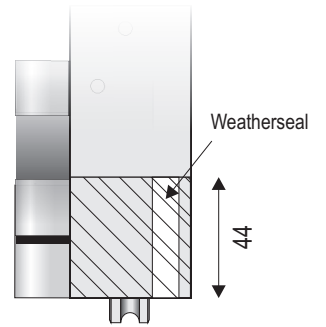
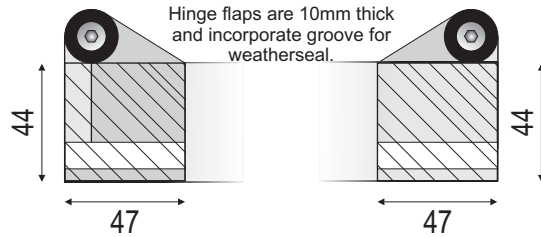

866x4.56 Bottom Roller - 56mm

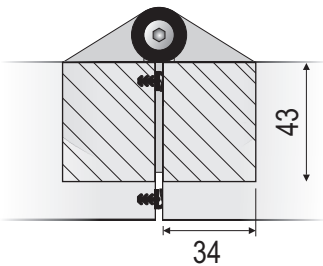

866x4.56 ROLI / LORI Bottom Rollers - 56mm

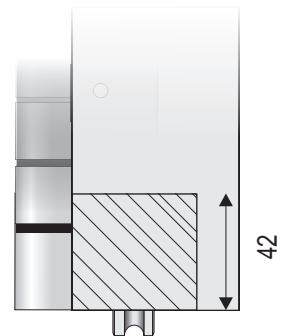
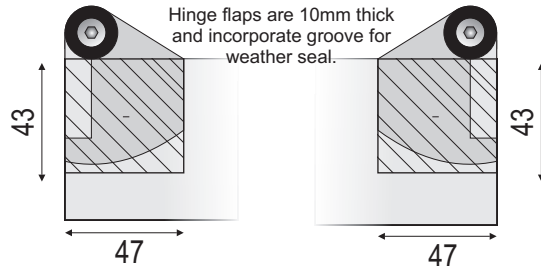

2) Top guide cut out details;

866x6 Top Guide

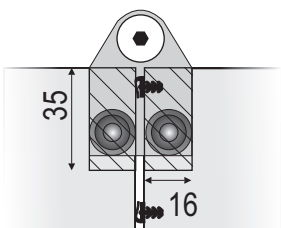

866x6 ROLI / LORI Top Guide

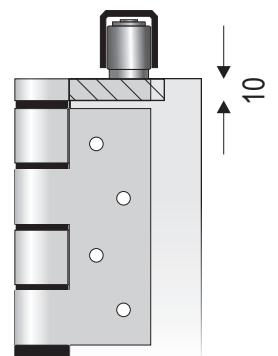
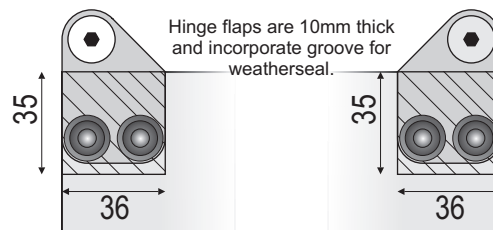

3) When cutting in the hinges & hardware please note that on the outside of the doors the top guide hinges are higher on the door than normal. Therefore, ensure the hinges on the jamb line up correctly with the top guide & bottom roller hinges to ensure continuity (unless door construction prohibits this). On the inside be wary not to mount them too high or they may foul the frame detail.

Also note the hinge handle is located between leaves 1 & 2 as the middle hinge and between 3 & 4 where a 4 or 5 door kit is used.

Router door 2 (& 4) to receive flush bolts both top & bottom

4) Router the frame and door 2 (&4) to receive the weatherseal. Also router the bottom of the doors on the external face to receive the brush strip. See details below;

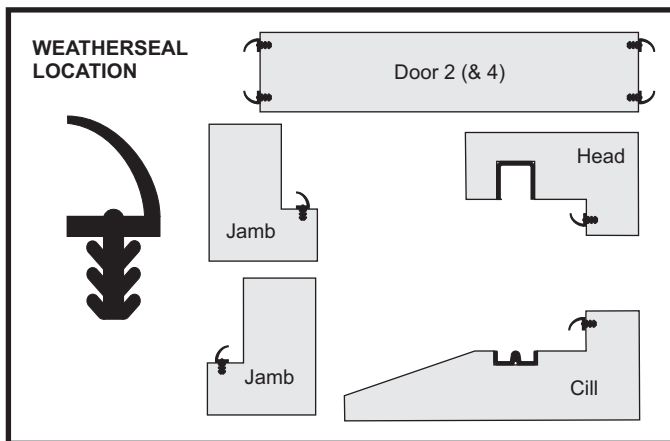
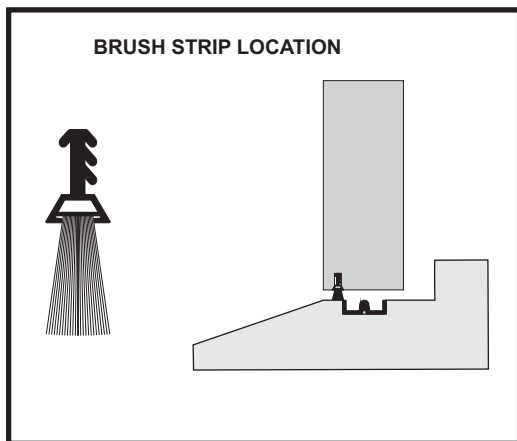

4

Assembly Order - Once the frame has been installed follow the guidelines below;

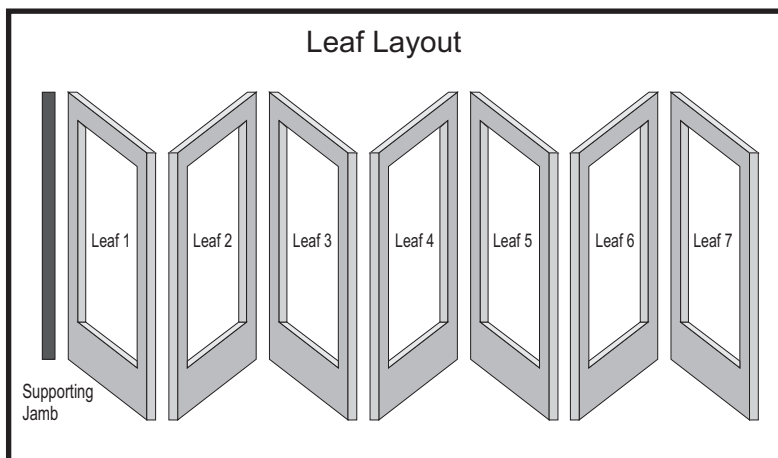

1) Mount the track & channel into the frame. Ensure all screws are fully countersunk in the top channel. Remember that odd number leaf systems do not require track under the free swinging door. In these cases position tracks & channel so that the end of the track aligns with the guide & roller resting positions when doors are in the closed position. This may leave a gap at the hinged jamb end of the doors which will then aid water egress. If track has to be cut to size then allow 10mm gap at the jamb.

2) Mount the 1st leaf to the supporting jamb with 3 hinges.

3a) **2 Leaf Layout** - Mount 2nd leaf to 1st leaf with 2 hinges & 1 hinge handle in centre. Ensure doors are supported until end roller & guides are installed. Ensure rollers and guides run freely.

3b) **3 Leaf Layout** - Mount 3rd leaf to 2nd leaf with 1 top guide, 1 hinge & 1 bottom roller. Ensure rollers and guides run freely.

3c) **4 Leaf Layout** - Mount 4th leaf to 3rd leaf with 2 hinges & 1 hinge handle in centre. Ensure doors are supported until end roller & guides are installed. Ensure rollers and guides run freely.

3d) **5 Leaf Layout** - Mount 5th leaf to 4th leaf with 1 top guide, 1 hinge & 1 bottom roller. Ensure rollers and guides run freely.

3c) **6 Leaf Layout** - Mount 6th leaf to 5th leaf with 2 hinges & 1 hinge handle in centre. Ensure doors are supported until end roller & guides are installed. Ensure rollers and guides run freely.

3d) **7 Leaf Layout** - Mount 7th leaf to 6th leaf with 1 top guide, 1 hinge & 1 bottom roller. Ensure rollers and guides run freely.

4) You have now installed one suite. If you have 2 suites meeting you must now repeat the above steps.

5) Attach relevant locking & handles to system.

6) Test system & ensure all fixings are secure.

7) It is essential that when an odd leaf system is used the swinging end leaf is held by the magnetic door catch during folding/unfolding to ensure that it does not swing freely and potentially cause injury.

Due to this system being bottom rolling the need for adjustment is unlikely.

It is strongly recommended that you have an experienced craftsman toe & heel a fully glazed door set. This can improve the operation and longevity of the system.

Should you experience problems or need any further help please contact us on 01708 891515.

MAINTENANCE - Periodically check track for debris and clean fittings with soap & water.

5

Alternative Cill Details & Layouts - Details showing amendments required should you want the doors folding inside or a flat threshold.

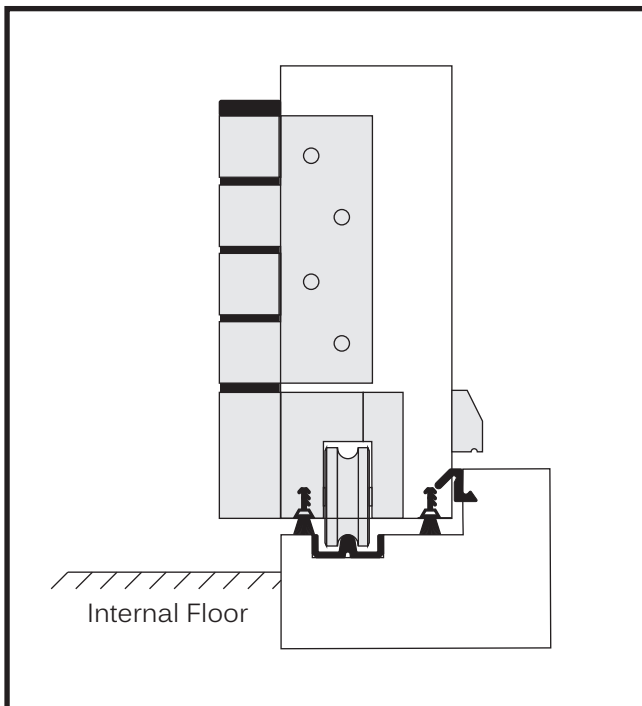

For inward folding doors please amend the cill detail as shown. You can also add a drip bar onto the door but it must not protrude more than 10mm from the face of the door otherwise the doors will foul each other when folded.

Do not forget to reverse the head detail as well!

The hinge handle will need to be replaced by a standard hinge as you need to push the door against the cill to lock the flush bolts.

You can also install a 2nd set of brush seals per door if required.

Again a drip bar can be fitted if required.

Ensure that the external floor has a gradient sloping away from the door. Ideally there should also be a storm drain placed after the gradient to aid water moving away and to stop water being pushed back by strong winds.

This arrangement should only be considered as a last resort and confined to conservatory or commercial property use.

